



# BLACK SNAKE

NEXT GENERATION AIR TOOLS

## 1/2" RATCHET WRENCH

**RMAX-RATC12**



### Specifications

- Max Torque 50 Ft Lbs / 68 Nm
- Length 256 mm
- Low Noise 79 dB

### Warranty Statement

Thank you for purchasing this Endeavour "Black Snake" Ratchet Wrench. Endeavour Tools guarantees this impact wrench against defects in material and workmanship for a period of **24 months from date of purchase**.

- Endeavour Tools warrants the quality of these goods against defects in material and workmanship only.
- Defective goods shall only be replaced, repaired or the purchase price refunded if:
  - the customer notifies Endeavour Tools by providing a full report describing the defect in writing within 7 days of discovery of the defect; and
  - the notification above provided to Endeavour Tools is prior to the expiry of the warranty period; and
  - the customer forwards the defective goods together with proof of purchase from Endeavour Tools or its authorised distributor at their expense, within 14 days of any request by Endeavour Tools to do so; and
  - the goods since the date of delivery to the customer have been properly maintained, store and housed and the goods have not been abused or modified; and
  - Endeavour Tools determines that there is a defect due to faulty workmanship or the use of a defective material.
- Endeavour Tools may replace or repair the defective good (or part thereof) or refund the purchase price of the defective good at its option.
- Endeavour Tools shall not be responsible for any loss or damage arising from or in any way connected with the use of the goods.
- To the maximum extent permitted by law, a claim in respect to a defective good shall not be permitted in the event that the goods have not been installed, used, maintained, or housed in a proper and workmanlike manner or in accordance with the usual standards or manufacturers specifications or instructions or if the goods have been modified, repaired or altered by any person apart from Endeavour Tools.

**Notwithstanding our warranty terms above, our goods come with guarantees that cannot be excluded under the Australian Consumer Law. You are entitled to a replacement or refund for a major failure and for compensation for any other reasonably foreseeable loss or damage. You are also entitled to have the goods repaired or replaced if the goods fail to be of acceptable quality and the failure does not amount to a major failure.**

**The benefits under our warranty are in addition to other rights and remedies under a law in relation to the goods. Warranty provided by and warranty claims should be submitted to the address below.**



### Warning:

Rated RPM Of The Accessory Used Must Exceed The Maximum Tool RPM Shown



For safety, performance and maximum durability of parts DO NOT operate this tool above 90 PSI.

Lubricate the air motor daily with quality air tool oil



**endeavourtools**  
Innovation - Performance - Quality

Endeavour Tools PTY LTD  
ABN 13 006 307 213

sales@endeavourtools.com.au  
www.endeavourtools.com.au

Suite 1/2, 12-18  
Victoria Street East  
Lidcombe NSW 2141  
Phone: +61 3 9753 3800 Fax: +61 2 9646 4222  
Phone: +61 3 9753 3933 Fax: +61 2 9646 5399

# RMAX-RATC12

## 1/2" RATCHET WRENCH



**BLACK SNAKE**  
NEXT GENERATION AIR TOOLS

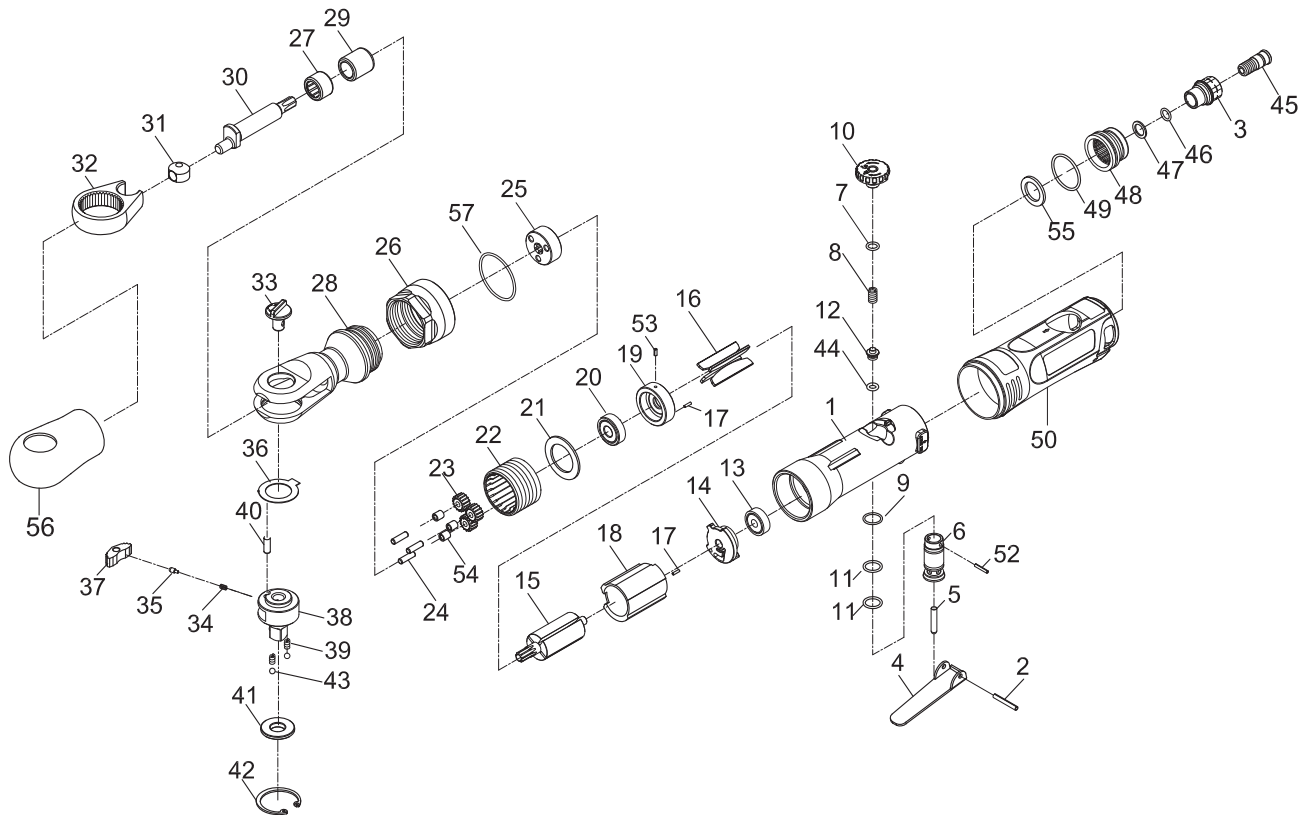

Index No.	Parts No.	Description	Index No.	Parts No.	Description
1	33-301301	Housing	29	30129	Bushing
2	50102	Spring Pin (Ø3×22L)	30	33-301330	Crank Shaft
3	522203-21	Air Inlet	31	33-301331	Drive Bushing
4	33-301304	Throttle lever	32	33-301332	Yoke
5	33-301305	Throttle Valve	33	33-301333	Reverse Button
6	33-301306	Bushing	34	33-301334	Spring
7	72804	O-Ring (6.5×1.5)	35	33-301335	Lock Pin
8	33-301308	Spring	36	30136	Washer
9	OR01104103	O-Ring (11.4×1.25)	37	30137	Ratchet Pawl
10	33-301310	Knob	38	31138	Ratchet Anvil 1/2"
11	OR01007105	O-Ring(2) (10.7×1.5)	39	30139	Spring (2)
12	33-301307	Throttle Valve	40	30140	Pin (Ø4.5×12.7L)
13	052213	Ball Bearing (696ZZ)	41	34-301341	Thrust Washer
14	301114	Rear End Plate	42	30142	Retainer Ring (RTW-31.5)
15	30115	Rotor	43	30143	Steel Ball (2) (5/32")
16	30116	Rotor Blade(4)	44	30107	O-Ring (3.8X1.9)
17	30117	Pin(2) (Ø1.5×6L)	45	33-301341	Fixed Shaft
18	50118	Cylinder	46	OR00705105	O-Ring (7.5×1.5)
19	33-301319	Front End Plate	47	522243	Washer
20	030120	Ball Bearing (608ZZ)	48	33-302311	Deflector
21	30121	Washer	49	OR02607108	O-Ring (26.7×1.78)
22	30122	Thread Ring Gear	50	33-301352	Grip
23	33-3013L23	Idler Gear (3)	52	SP02001200	Spring Pin (2×12L)
24	30124	Idler Gear Pin (3) (Ø4×13.8L)	53	70117	Spring Pin (2×5L)
25	30125	Idler Gear Plate	54	80225	Bushing (3)
26	301126	Clamp Nut	55	33-302312	Damping Material
27	030129	Needle Bearing	56	30152	Rubber Hat
28	33-301328	Ratchet Housing	57	P91237	O-Ring (29.4×3.1)