



BLACK SNAKE
NEXT GENERATION AIR TOOLS

1/4" Air Die Grinder

RMAX-DG



Specifications

A high powered unit, yet with low noise characteristics. Ideal for industrial applications.

- Horsepower: 0.5HP
- RPM: 22,000
- Avg Air Cons: 3.5 CFM
- Length: 178mm
- Includes 1/4" collet

Warranty Statement

Thank you for purchasing this Endeavour "Black Snake" Air Die Grinder. Endeavour Tools guarantees this die grinder against defects in material and workmanship for a period of **24 months from date of purchase**. This warranty excludes consumable items in this kit.

- Endeavour Tools warrants the quality of these goods against defects in material and workmanship only.
- Defective goods shall only be replaced, repaired or the purchase price refunded if:
 - the customer notifies Endeavour Tools by providing a full report describing the defect in writing within 7 days of discovery of the defect; and
 - the notification above provided to Endeavour Tools is prior to the expiry of the warranty period; and
 - the customer forwards the defective goods together with proof of purchase from Endeavour Tools or its authorised distributor at their expense, within 14 days of any request by Endeavour Tools to do so; and
 - the goods since the date of delivery to the customer have been properly maintained, store and housed and the goods have not been abused or modified; and
 - Endeavour Tools determines that there is a defect due to faulty workmanship or the use of a defective material.
- Endeavour Tools may replace or repair the defective good (or part thereof) or refund the purchase price of the defective good at its option.
- Endeavour Tools shall not be responsible for any loss or damage arising from or in any way connected with the use of the goods.
- To the maximum extent permitted by law, a claim in respect to a defective good shall not be permitted in the event that the goods have not been installed, used, maintained, or housed in a proper and workmanlike manner or in accordance with the usual standards or manufacturers specifications or instructions or if the goods have been modified, repaired or altered by any person apart from Endeavour Tools.

Notwithstanding our warranty terms above, our goods come with guarantees that cannot be excluded under the Australian Consumer Law. You are entitled to a replacement or refund for a major failure and for compensation for any other reasonably foreseeable loss or damage. You are also entitled to have the goods repaired or replaced if the goods fail to be of acceptable quality and the failure does not amount to a major failure.

The benefits under our warranty are in addition to other rights and remedies under a law in relation to the goods. Warranty provided by and warranty claims should be submitted to the address below.



Warning:

Rated RPM Of The Accessory Used Must Exceed The Maximum Tool RPM Shown



For safety, performance and maximum durability of parts DO NOT operate this tool above 90 PSI.

Lubricate the air motor daily with quality air tool oil



endeavourtools
Innovation - Performance - Quality

Endeavour Tools PTY LTD
ABN 13 006 307 213

sales@endeavourtools.com.au
www.endeavourtools.com.au

50 Jellico Drive
Scoresby VIC 3179
Phone: +61 3 9753 3800
Fax: +61 3 9753 3933

Suite 1/2, 12-18
Victoria Street East
Lidcombe NSW 2141
Phone: +61 2 9646 4222
Fax: +61 2 9646 5399

RMAX-DG

1/4" Air Die Grinder



BLACK SNAKE
NEXT GENERATION AIR TOOLS

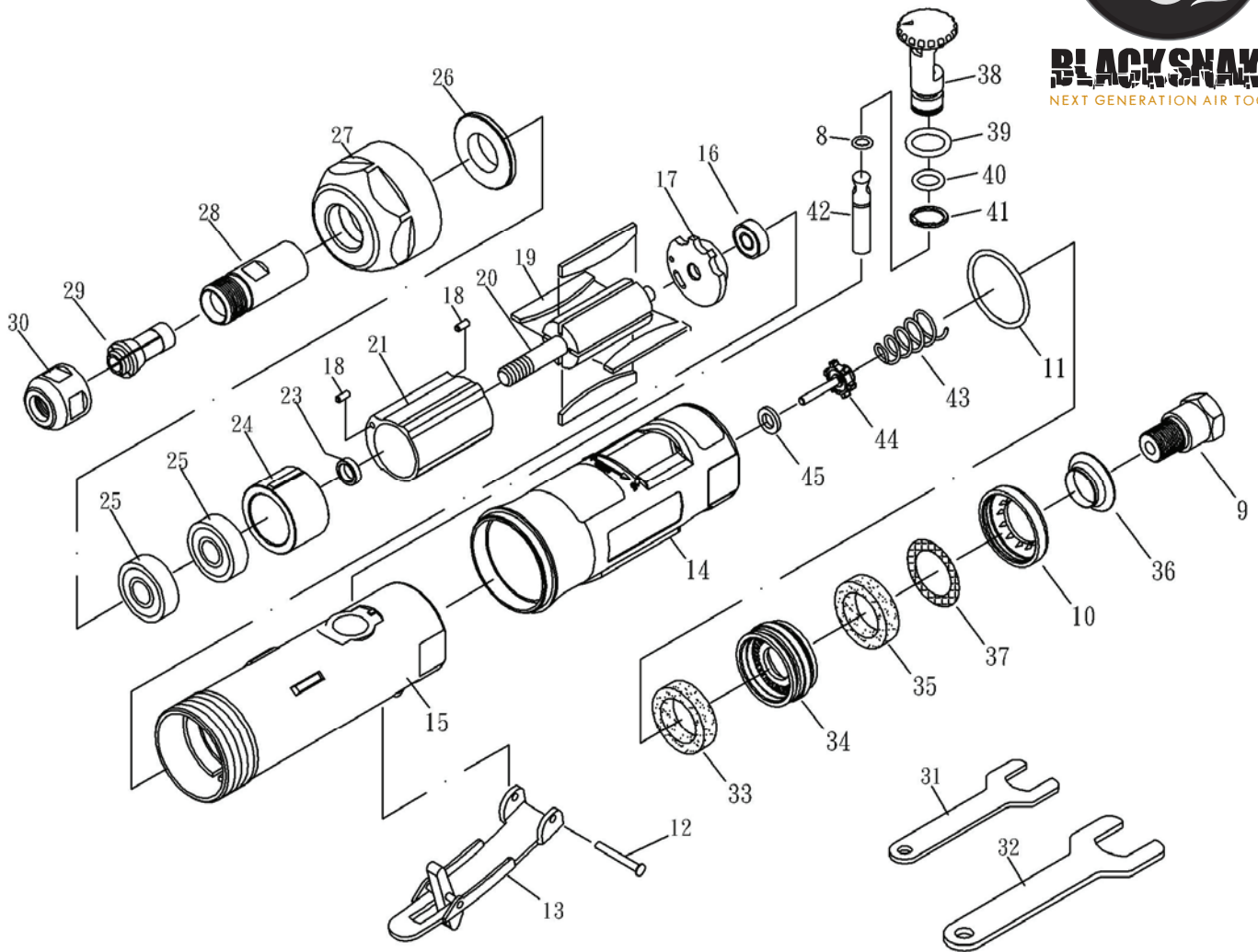

NO	PARTS NO	DESCRIPTION	Q'TY
08	OB-04	O-RING (3.5*1.4)	1
09	ST200A09	AIR INLET	1
10	ST20010	EXHAUST SLEEVE	1
11	70011	O-RING (26.7*1.78)	1
12	70432BK	SPRING PIN	1
13	ST80509	LEVER	1
14	ST200A14	PROTECTING RUBBER	1
15	ST200A15	HOUSING	1
16	20312	BEARING (696ZZ)	1
17	ST70017	REAR PLATE	1
18	70018	PIN	2
19	20019	ROTOR BLADE	4
20	ST288321	ROTOR	1
21	ST70021	CYLINDER	1
23	20022	BEARING SPACER	1
24	ST21023	FRONT PLATE	1
25	21024	BEARING (608ZZ)	2
26	20025	WASHER	1
27	ST20026	CLAMP NUT	1

NO	PARTS NO	DESCRIPTION	Q'TY
28	20027	SPINDLE	1
29	21036-1	COLLET	1
30	21037	COLLET NUT	1
31	BT21038-14	STOP SPANNER (14MM)	1
32	BT21039-19	STOP SPANNER (19MM)	1
33	ST20035A	SILENCER	1
34	ST20034	MUFFLER	1
35	ST20035	SILENCER	1
36	ST20036	MUFFLER BODY	1
37	ST20037	STAINLESS MESH	1
38	ST200A37	REGULATOR	1
39	OB-02	O-RING (P9)	1
40	ST288303	O-RING (P10)	1
41	OB-30	SNAP RING	1
42	ST200A33	VALVE STEM	1
43	ST200A43	SPRING	1
44	ST200A44	VALVE	1
45	ST200A45	WASHER	1

0303AC