



BLACK SNAKE

NEXT GENERATION AIR TOOLS

Composite Belt Sander

RMAX-BELT10



Specifications

- 10 x 330mm
- Avg Air Cons: 0.92 CFM
- RPM: 18,000
- Noise Level: 81 dBA
- Weight: 0.78 kg
- 1/4" BSP

Warranty Statement

Thank you for purchasing this Endeavour "Black Snake" belt sander. Endeavour Tools guarantees this impact wrench against defects in material and workmanship for a period of **24 months from date of purchase.**

- Endeavour Tools warrants the quality of these goods against defects in material and workmanship only.
- Defective goods shall only be replaced, repaired or the purchase price refunded if:
 - the customer notifies Endeavour Tools by providing a full report describing the defect in writing within 7 days of discovery of the defect; and
 - the notification above provided to Endeavour Tools is prior to the expiry of the warranty period; and
 - the customer forwards the defective goods together with proof of purchase from Endeavour Tools or its authorised distributor at their expense, within 14 days of any request by Endeavour Tools to do so; and
 - the goods since the date of delivery to the customer have been properly maintained, store and housed and the goods have not been abused or modified; and
 - Endeavour Tools determines that there is a defect due to faulty workmanship or the use of a defective material.
- Endeavour Tools may replace or repair the defective good (or part thereof) or refund the purchase price of the defective good at its option.
- Endeavour Tools shall not be responsible for any loss or damage arising from or in any way connected with the use of the goods. To the maximum extent permitted by law, a claim in respect to a defective good shall not be permitted in the event that the goods have not been installed, used, maintained, or housed in a proper and workmanlike manner or in accordance with the usual standards or manufacturers specifications or instructions or if the goods have been modified, repaired or altered by any person apart from Endeavour Tools.

Notwithstanding our warranty terms above, our goods come with guarantees that cannot be excluded under the Australian Consumer Law. You are entitled to a replacement or refund for a major failure and for compensation for any other reasonably foreseeable loss or damage. You are also entitled to have the goods repaired or replaced if the goods fail to be of acceptable quality and the failure does not amount to a major failure.

The benefits under our warranty are in addition to other rights and remedies under a law in relation to the goods. Warranty provided by and warranty claims should be submitted to the address below.



Warning:

Rated RPM Of Any Accessory Used Must Exceed The Maximum Tool RPM Shown



For safety, performance and maximum durability of parts DO NOT operate this tool above 90 PSI.

Lubricate the air motor daily with quality air tool oil



endeavourtools
Innovation - Performance - Quality

Endeavour Tools PTY LTD
ABN 13 006 307 213

sales@endeavourtools.com.au
www.endeavourtools.com.au

50 Jellico Drive
Scoresby VIC 3179
Phone: +61 3 9753 3800
Fax: +61 3 9753 3933

Suite 1/2, 12-18
Victoria Street East
Lidcombe NSW 2141
Phone: +61 2 9646 4222
Fax: +61 2 9646 5399

RMAX-BELT10

Composite Belt Sander



BLACK SNAKE
NEXT GENERATION AIR TOOLS

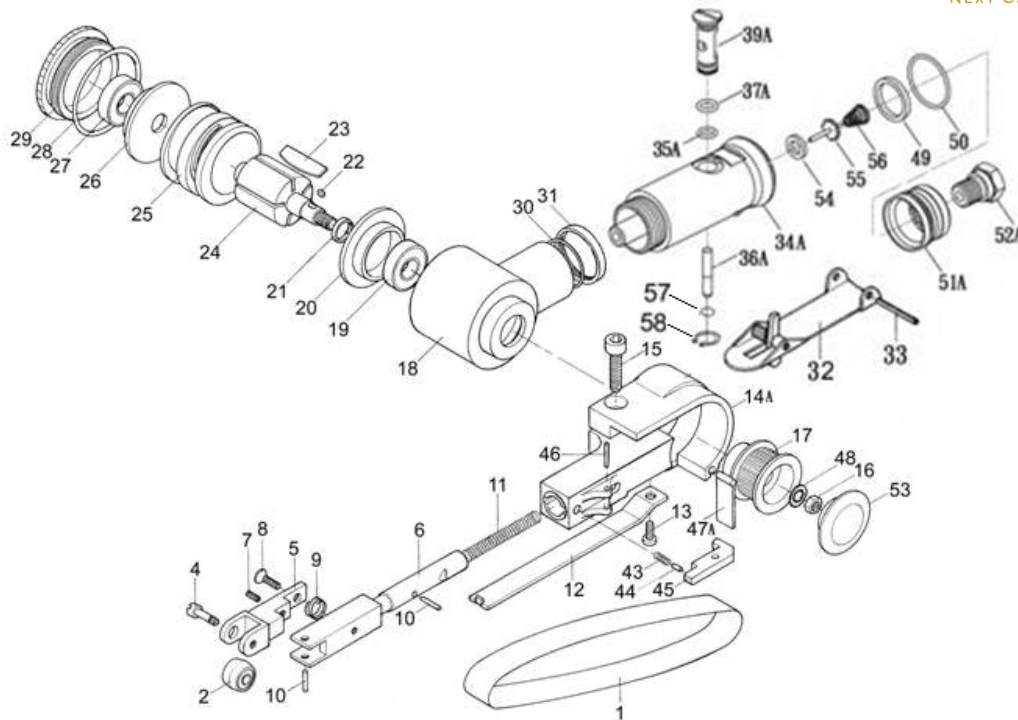

No.	Part No.	Description	Q'ty	No.	Part No.	Description	Q'ty
1	3103001	Grinding Belt (#80, #100, #120)	3	29	3103029	Motor Nut	1
2	3103002	Idle Pulley 10 Sub Assy	1 set	30	3103030	O-Ring	1
4	3103004	Idle Pulley Shaft 10	1	31	3103031	Lock Nut	1
5	3103005	Bracket 10	1	32	3103032	Throttle Lever	1
6	3103006	Tension Bar 10	1	33	3103033	Lever Pin	1
7	3103007	Set Screw 3x6	1	34A	3103034A	Motor Housing	1
8	3103008	Screw 3x8	1	35A	3103035A	O-Ring	1
9	3103009	Spring 1.0x7.2x6.5	1	36A	3103036A	Valve Stem	1
10	3103010	Spring Pin 3x10	2	37A	3103037A	O-Ring	1
11	3103011	Spring 1.0x4.0x35.5	1	39A	3103039A	Air Controller	1
12	3103012	Shoe 10	1	43	3103043	Spring	1
13	3103013	Screw 4x8	1	44	3103044	Lever Pin	1
14A	3103014A	Guard Sub Assy A	1	45	3103045	Tension Bar	1
15	3103015	Hexagon Socket Head Bolt 5x12	1	46	3103046	Lever Pin	1
16	3103016	Hexagon Nut M6	1	47A	3103047A	Dust Cover	1
17	3103017	Drive Pulley	1	48	3103048	Washer	1
18	3103018	Housing	1	49	3103049	Siliencer	1
19	3103019	Ball Bearing	1	50	3103050	O-Ring	1
20	3103020	Front End Plate	1	51A	3103051A	Air Controller	1
21	3103021	Spacer	1	52A	3103052A	Air Inlet	1
22	3103022	Sunk Key	1	53	3103053	Cap	1
23	3103023	Rotor Blade	5	54	3103054	Seal	1
24	3103024	Rotor	1	55	3103055	Valve Stem	1
25	3103025	Cylinder	1	56	3103056	Spring	1
26	3103026	Rear Plate	1	57	3103057	O-Ring	1
27	3103027	Ball Bearing	1	58	3103058	Snap Ring	1
28	3103028	O-Ring	1				