

SAC Clutch Tool Master Kit

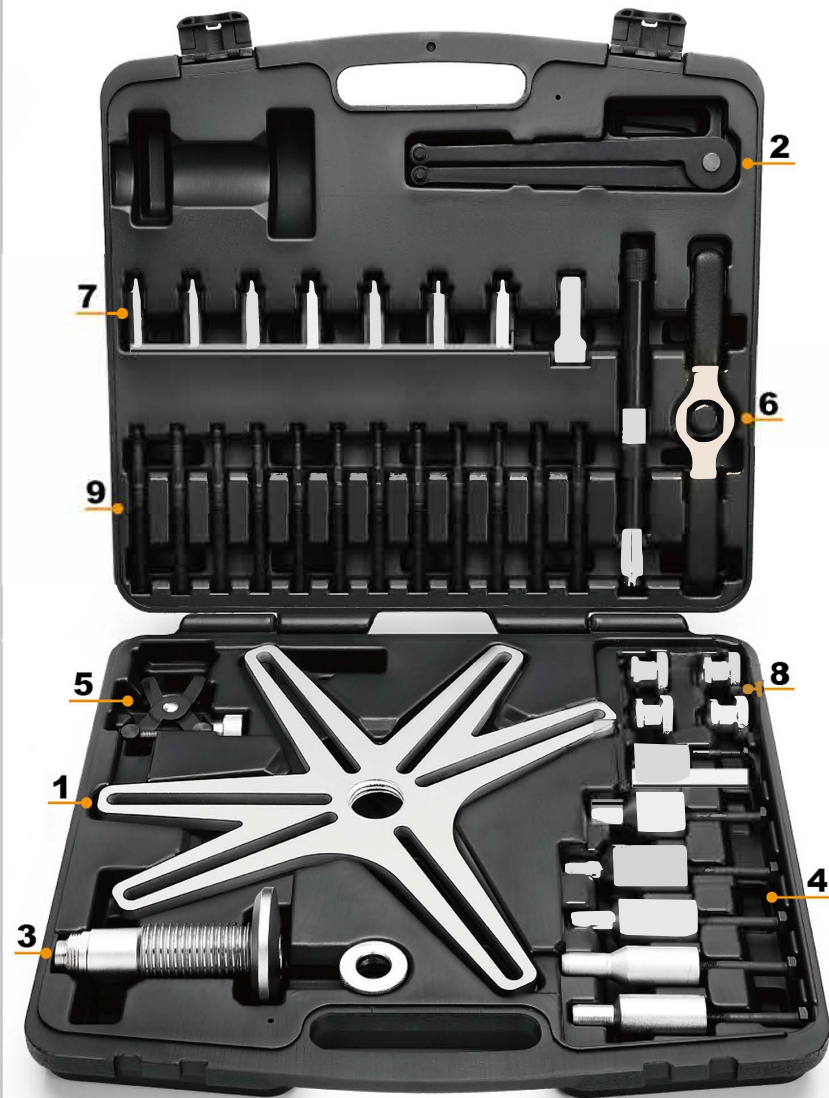

1. Clamping tool

- For 6 or 8 locking holes

2. Face spanner

3. Compression strut

4. Clutch mandrel set (BMW)

- 15mm x 23mm
- 15mm x 26.5mm
- 15mm x 28mm
- 15mm x 32.5mm
- 15mm x 32.5mm (sleeve)
- 15mm x 34mm

5. Clutch resetting tool

6. Handle for clamping tool

7. Clutch centering tools

- Centering handle / Handle adapter
- Clamping cone 15-22mm / 22-28mm
- Centering pin 12mm / 14mm / 15mm
16mm / 17mm / 18mm / 19mm

8. Knurled nuts for threaded bolts (4 pcs)

9. Three sets of 4 threaded bolts

- M6x1.0 / M7x1.0 / M8x1.25



• If the old clutch cover is to be re-used, it must first be reset. The adjuster ring can be turned back with clutch resetting tool.

• The face spanner is a releasing tool for the SAC clutches with locking element used on VW/Audi/Skoda/Seat.

- This kit allows the professional disassembling and assembling of all self adjusting clutches (SAC).
- The pre-tightening of the pressure plate is required in order to avoid clutch deformations.
- The 6-arms plate has been designed for SAC clutches with 6/8 locking holes.