

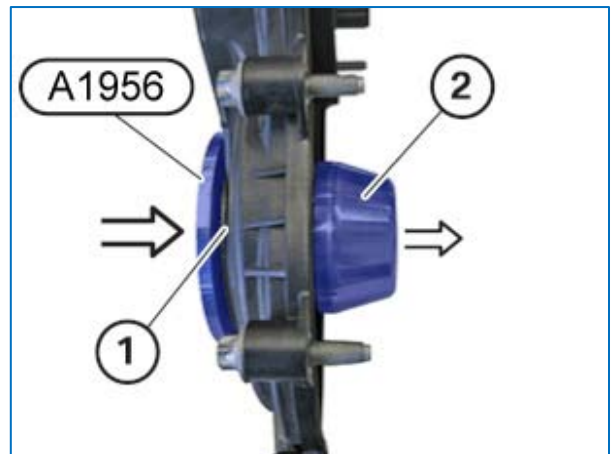

ET1965A

BMW (B37 / B38) CRANKSHAFT FRONT SEALING RING INSTALLER



- The crankshaft radial sealing ring has both a lip and a protective lip.
- This tool is designed to prevent damage when assembling the cover to the crankshaft flange.
- Application: BMW (B37C / B37D / B38A / B38B)
- **OEM equiv:** 2 357 900