

# ET1867A

**BMW (B37/B47/B48/B57/B58/N47/N57)**

## CRANKSHAFT FRONT OIL SEAL INSTALL KIT

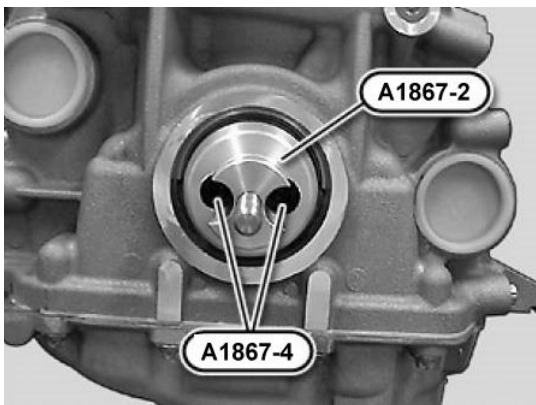
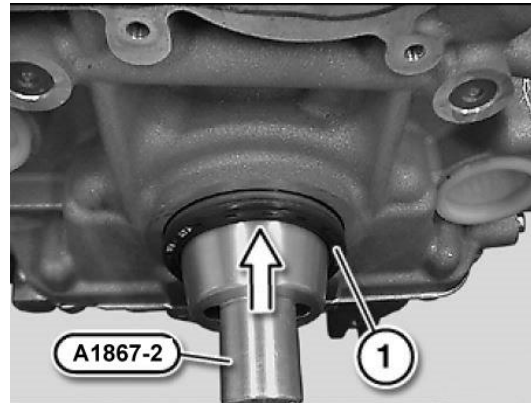
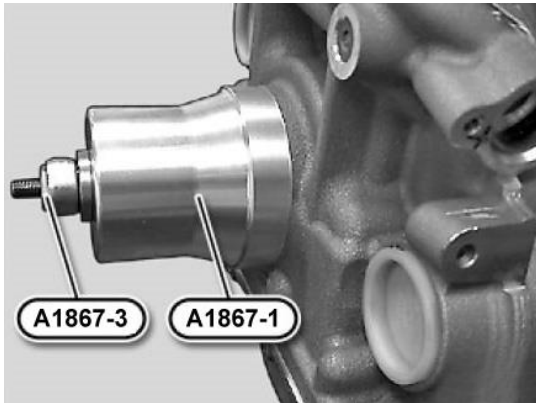

■ For replacing the crankshaft front seal.

■ Application: BMW

1er, 2er (E81, E82, E87, E88, F20, F21, F22, F23, F45, F46, F87) 114d, 116d, 118d, 120d, 123d, 125d, 120i, 125i, 220i, 230i

3er, 4er (E90, E91, E92, E93, F30, F31, F32, F33, F34, F36, F80, F82, F83, G20, G21) 316d, 318d, 320d, 325d, 330d, 335d, 320i, 330i, 420i, 430i

5er, 6er (E60, E61, E63, E64, F11, F12, F13, F90, G30, G31, G32) 520d, 525d, 530d, 535d, 550d, 640d, 520i, 530i

7er (F01, F02, F03, F04, G11, G12) 730d, 740d, 750d  
X1, X3, X5, X6 (E70, E71, E83, E84, F25, G01, G02, G11, G12) 16d, 18d, 20d, 25d, 30d, 35d, 40d, 50d, 20i, 30i

**Mini** One, Cooper D/SD (F54, F55, F56, F57, F60)

**Pacemann** (R57, R55, R57, R58, R57, R60, R61)

■ **BMW OEM Equiv:** BMW 118 800