

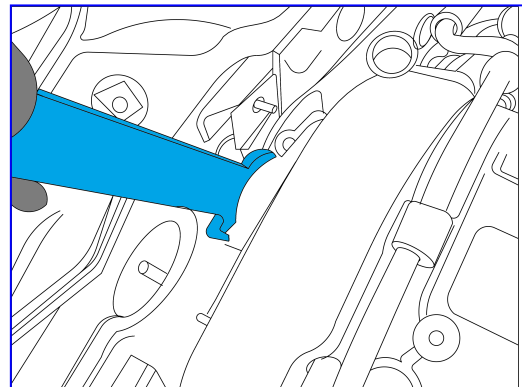

endeavour

ET1704D

BMW (B38 / B48) TIMING TOOL KIT

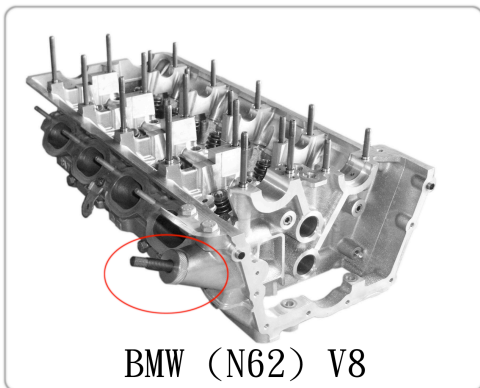
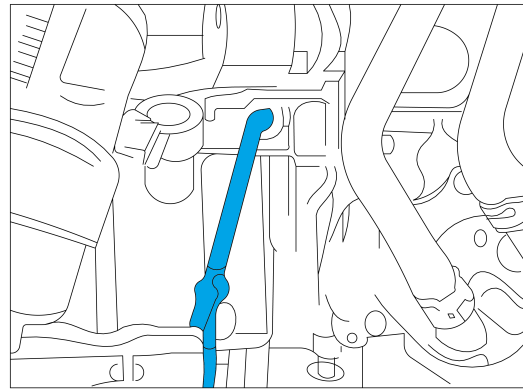
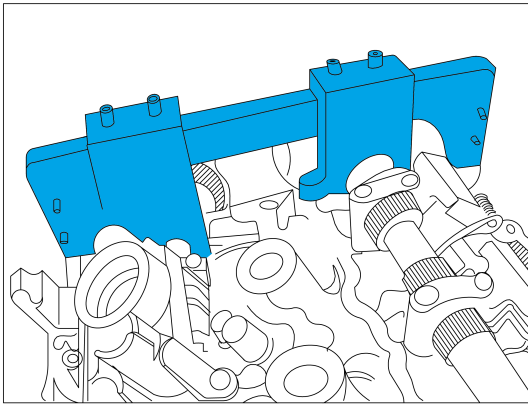
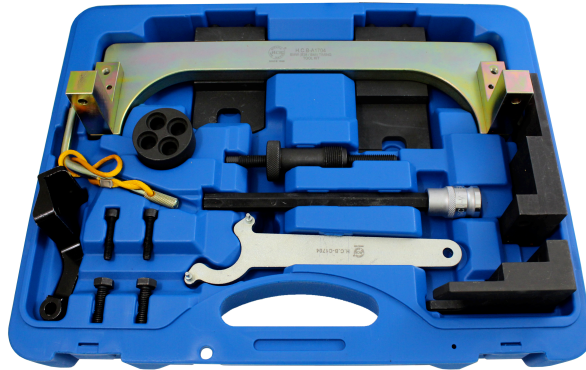

- Designed for locking crankshaft and camshafts in timing position while servicing BMW B38 / B48 engine.
- For setting the crankshaft at TDC. (Longitudinal installation with automatic transmission only).
- Applications: BMW B38, B48 engines.
- **BMW OEM Equiv: 2 358 122, 2 288 380, 2 365 488**