

# ET1642A

## VW/AUDI CAMSHAFT TIMING CHAIN TOOL KIT (4.2 L)

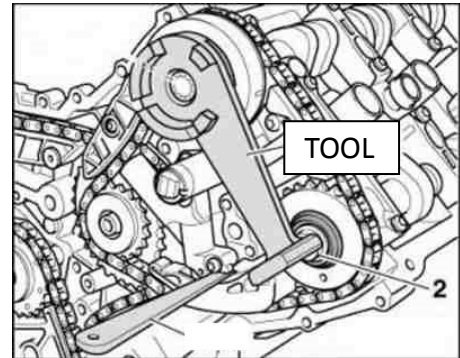

Layout no.		Description	OEM Equiv	Remark
1		AUDI SETTING GAUGE	T40047	2 PCS
2		VW/AUDI CAMSHAFT BAR	T10068A	2 PCS
3		VW/AUDI ENGINE TIMING TOOL KIT (TFSI)	T40046	2 PCS
4		Blow Mould Case W/EVA		

- For locking camshafts when checking valve timing
- Specially designed to hold and align the camshaft.
- Specially designed to install Hall sender screens into crankshaft adjuster when setting the crankshaft timing
- Engine Model V8 BAT 4.2 engines
- **Application:** Audi A6L, A8L 4.2L engines
- **Engine model:** 6-cyl. injection engine (4-valve), 8-cyl. injection engine (W8), 12-cyl. injection engine (W12).  
Golf 1998-newer, Bora 1999-newer, Passat 1997-newer, Sharan 1996-newer, Touareg 2003-newer, Phaeton 2003-newer, Transporter 1991-newer, Audi A8 1994-newer, Audi TT 1999-newer
- **VW OEM Equiv:** T40046 | T40047 | T10068A