

STEP4

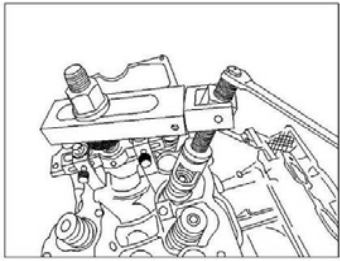

STEP4

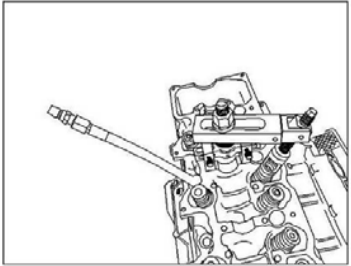

STEP4

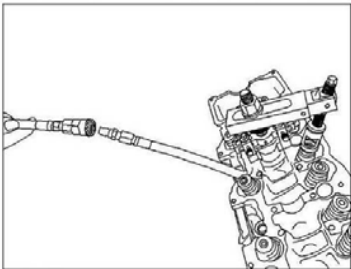

STEP4

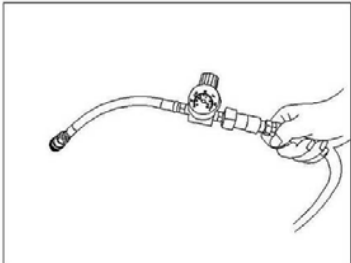

STEP4

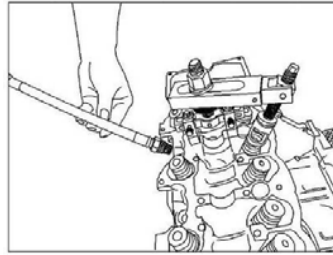

STEP4

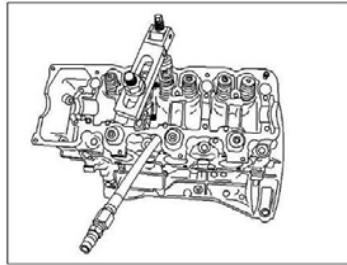

STEP4

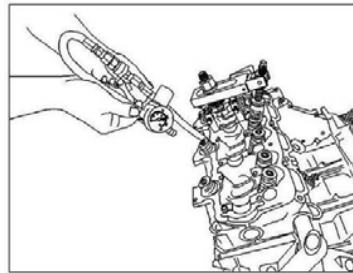

STEP4

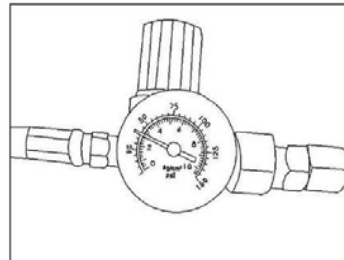

# ET1376C

UNIVERSAL VALVE SPRING REMOVER /  
INSTALLER PAT.M411316 & M409923 DE  
PAT.



B1376-23 (M12x P.1.25)  
can use on N63(X6 4400 cc.)



B1376-24 (M6 x P 1.0 x 85  
L)



B1376-25 (M6 x P1.0 x 30  
L) For BMW N20



VIDEO



## 2. instruction and application:

\* Replace valve spring and oil seal of valve rod on car, without removing head gasket.

\* Works great in the narrow engine room.

\* Enormous time saving for replacement of valve stem seals.

\* Apply for European, American, and Japanese cars. Such as BENZ, BMW, VOLVO, TOYOTA TERCEL, MITSUBISHI SAVRIN, VW, FORD etc. Especially suitable on BENZ V6 Engine and BMW V8 Engine.

\* Application engine model:

BENZ M102, M103, M104, M111, M112, M113, M271, M272.

BMW N20, N42, N46, N52, N62, M54, M56, M60

No. 18 -	BMW N52, N54/ Mercedes-Benz M272, M273
No. 19	BMW N52, N54/ Mercedes-Benz M272, M273
No. 20	BMW E65, E66, N52, N54/ Mercedes-Benz M272, M273
No. 21	BMW N42
No. 22	Mercedes-Benz M102, M103
No. 23	BMW N63 (X6 4400 c.c.)
No. 24, No. 25	BMW N20

*Note: Please tighten the blue parts*

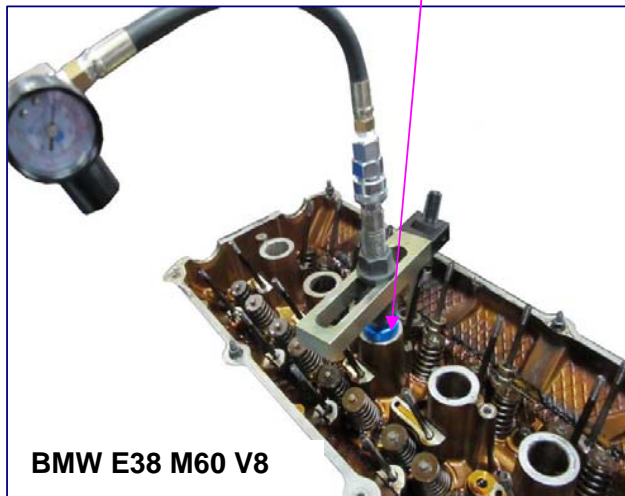

STEP3



STEP3

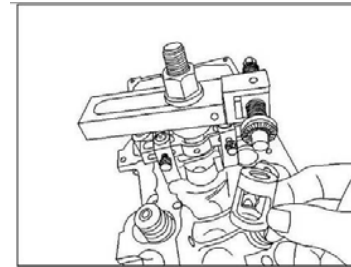

STEP3

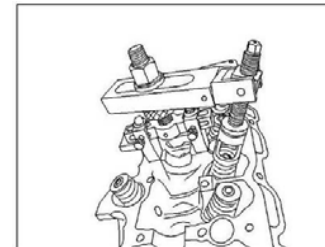

STEP4

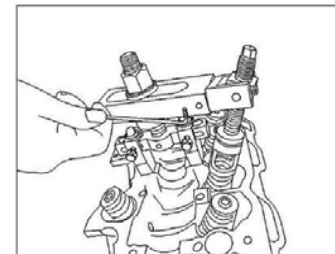

STEP3

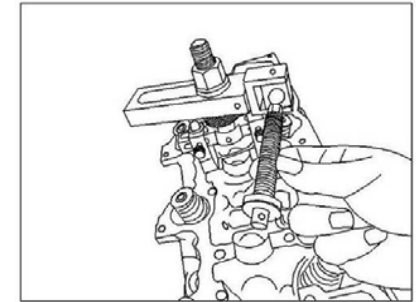

STEP3

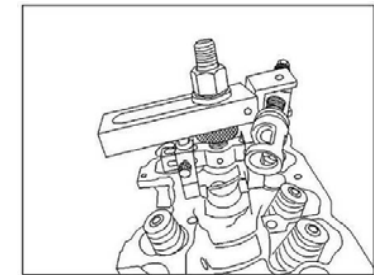

STEP3

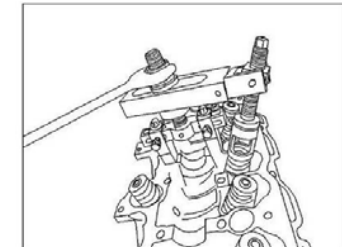

STEP4

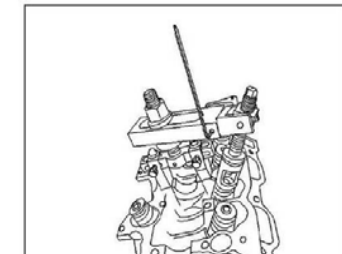

P11

STEP2

STEP2

P2

STEP2

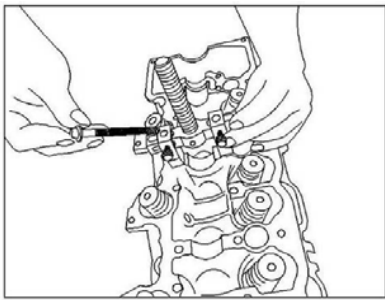

STEP2

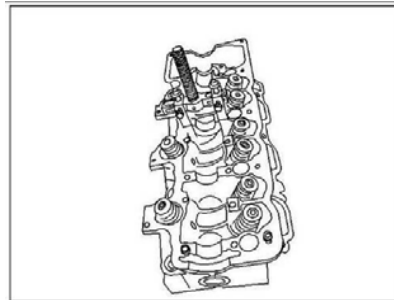

STEP2

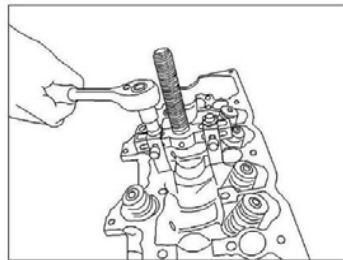

STEP2

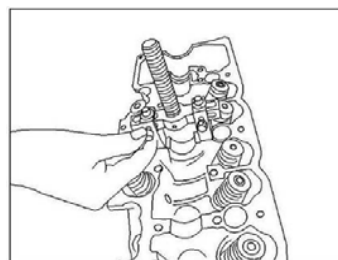

STEP3

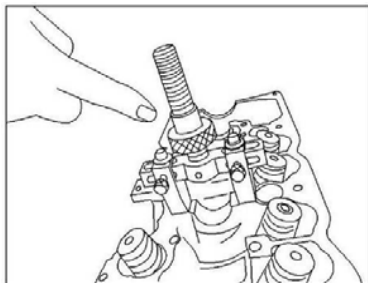

STEP3

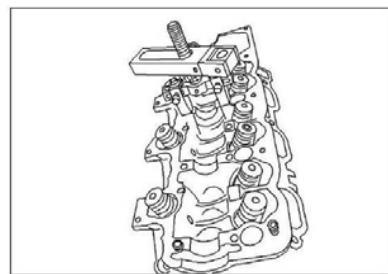

STEP3

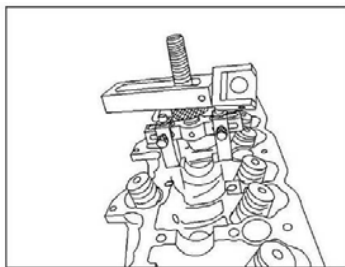

STEP3

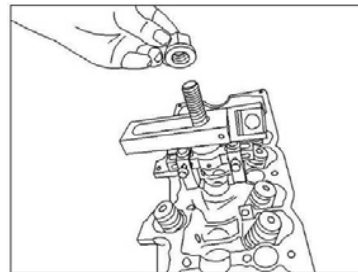

VW.AUDI



BMW N62

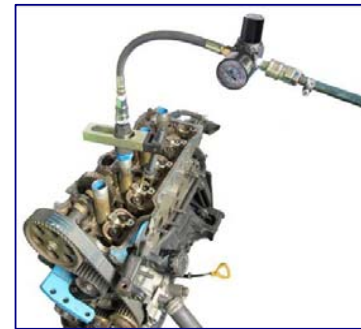

TOYOTA



BENZ M272



BENZ M112(V6)



MITSUBISHI SAVRIN

# VERTICAL ENGINE

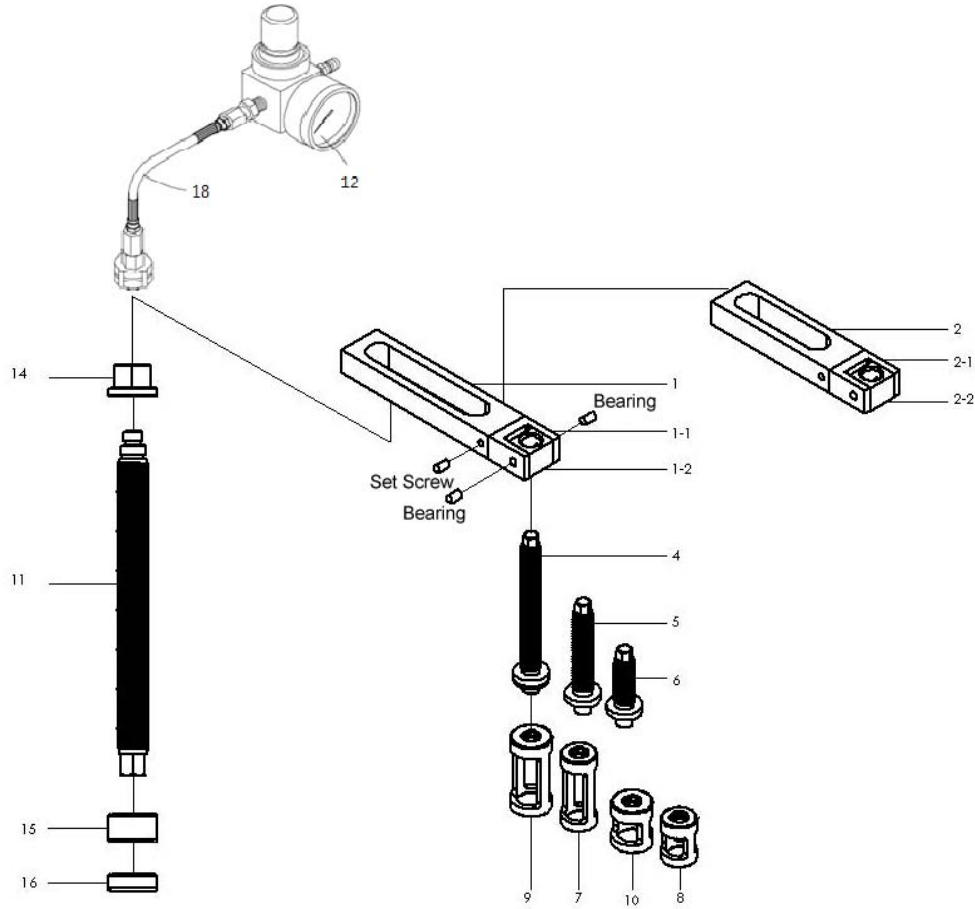

STEP2

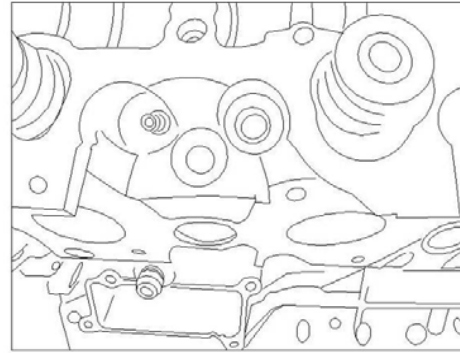

STEP2

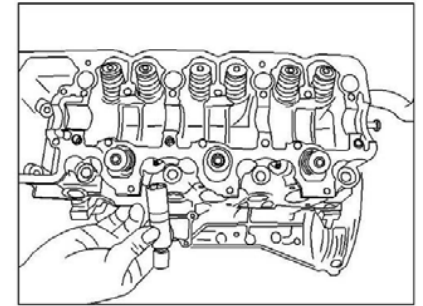

STEP2

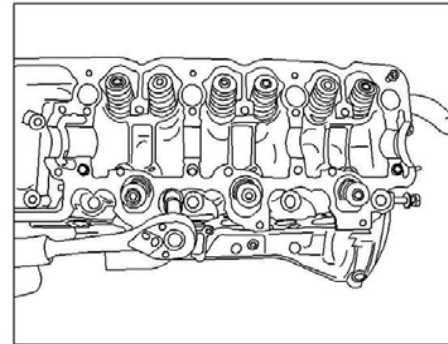

STEP2

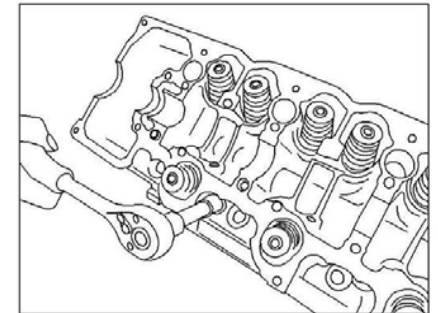

STEP2

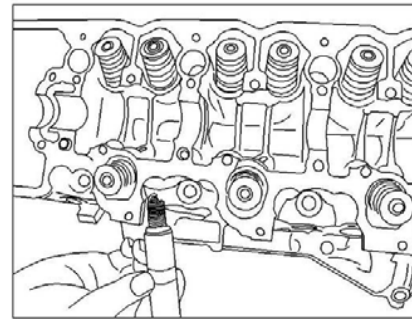

STEP2

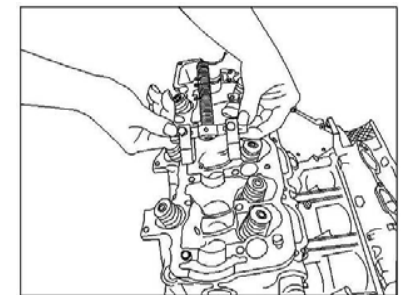

P9

STEP1

STEP2

P4

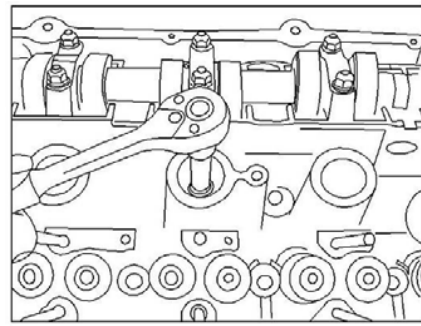
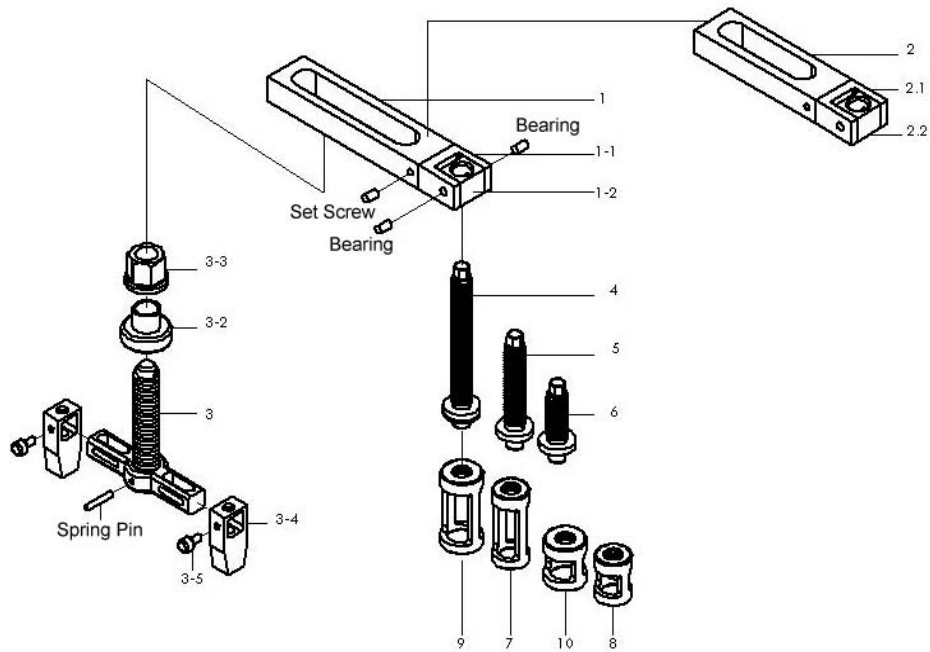
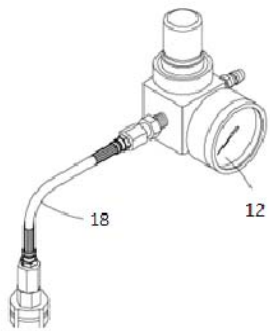

STEP3

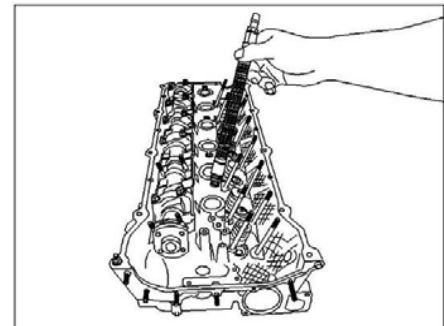

STEP4

Note: Please tighten the blue parts

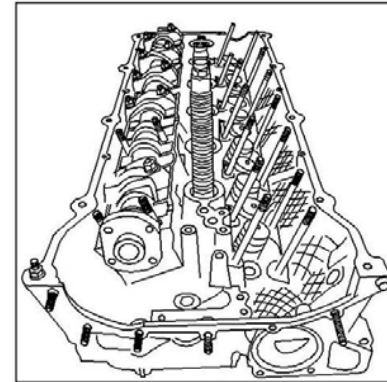

STEP5

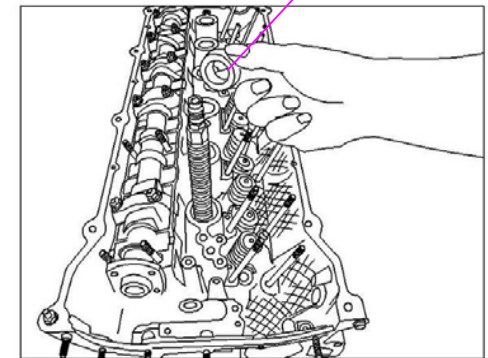

STEP6

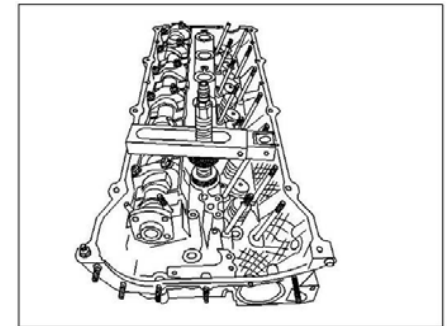
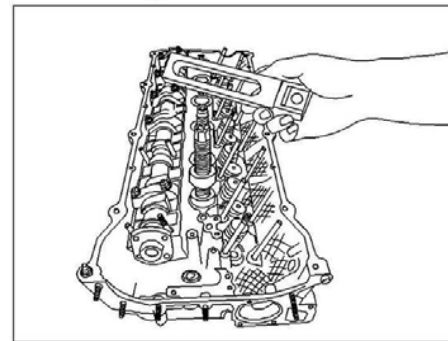

STEP7

STEP8

STEP13



STEP1



STEP7

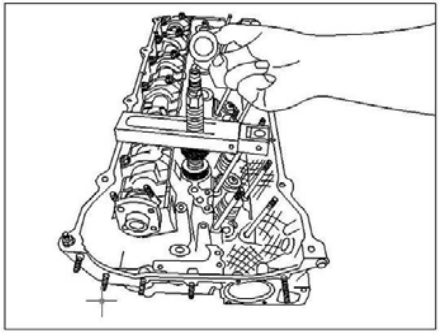

STEP8

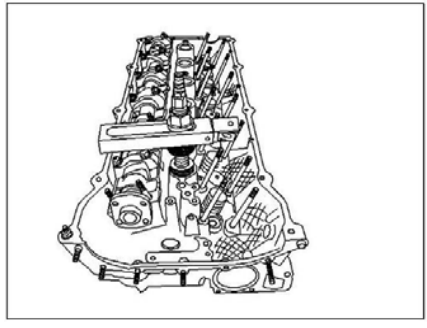

STEP9

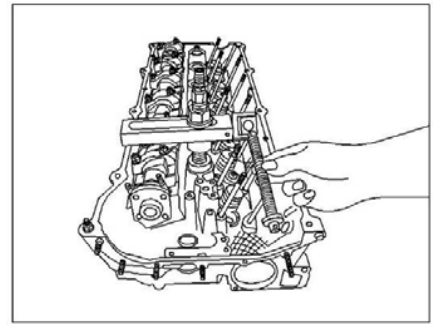

STEP1

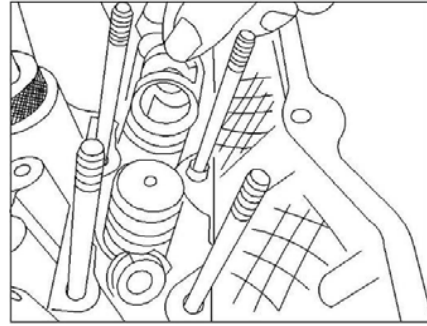

STEP1

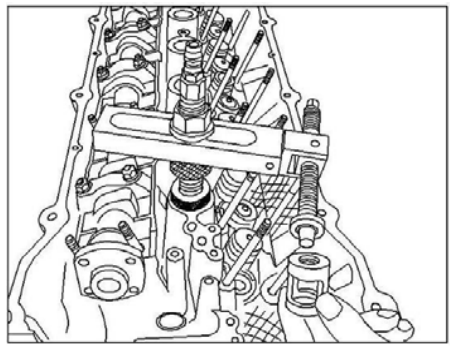

STEP1

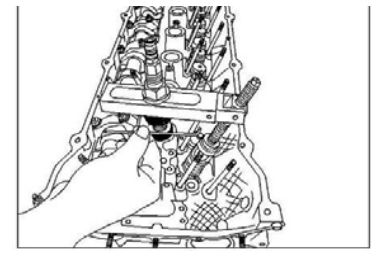
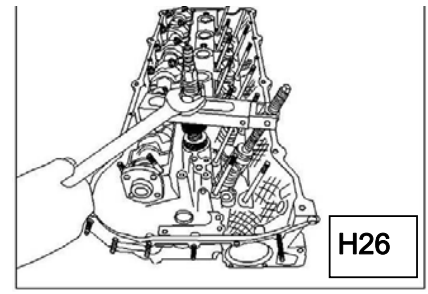
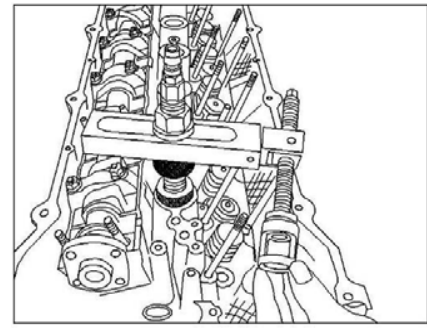

STEP1

STEP1

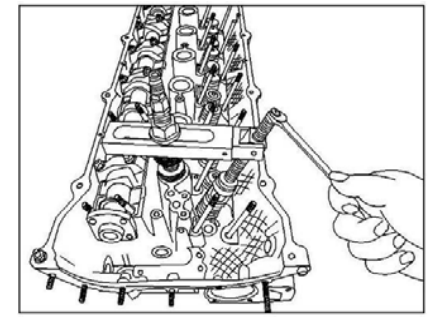
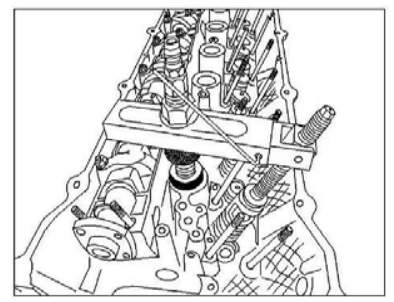

Use 2.5 mm HEX key to tighten

Use H17 Adjustable Wrench to tighten

STEP1

STEP1

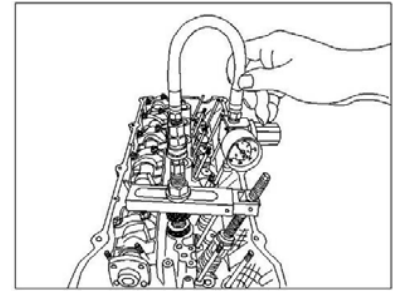
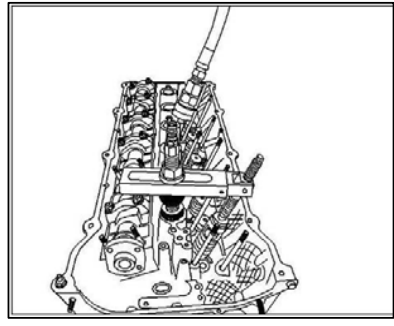

STEP1

