

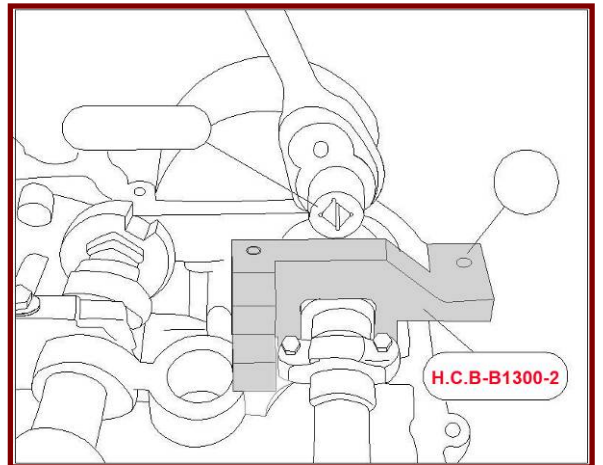

ET1300C

MINI COOPER (N12 | N14 | N16) TIMING TOOL KIT

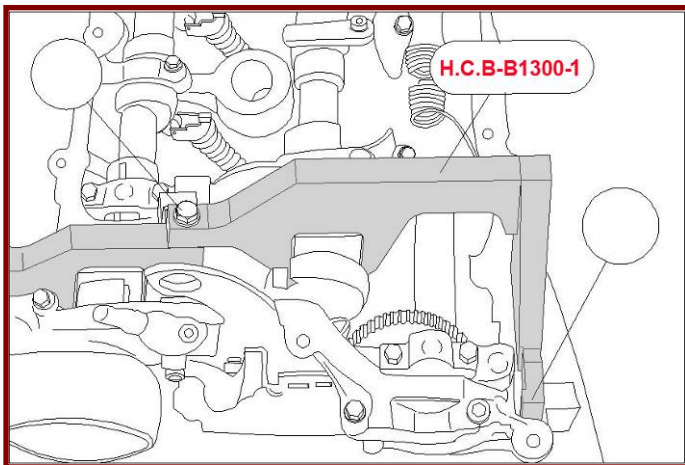

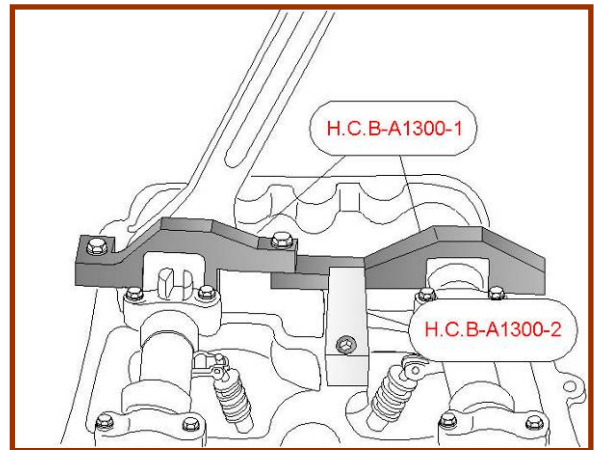
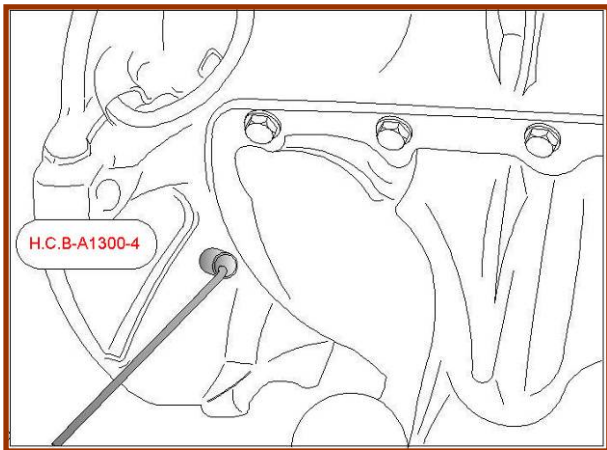
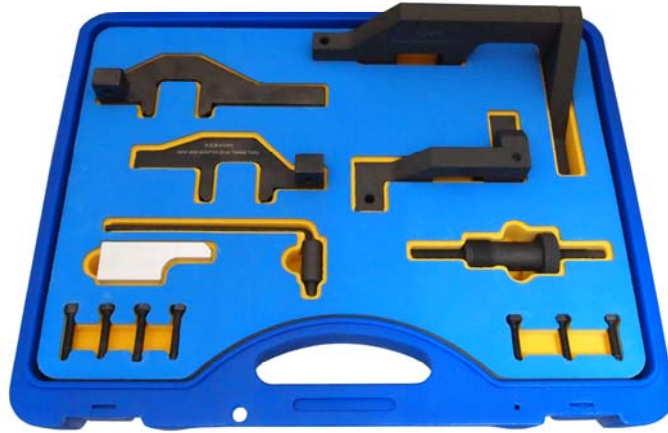
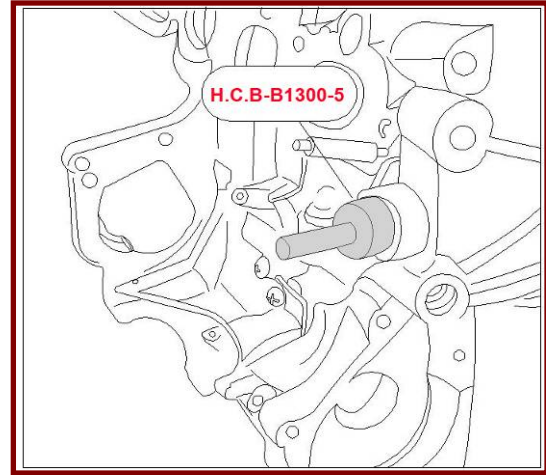
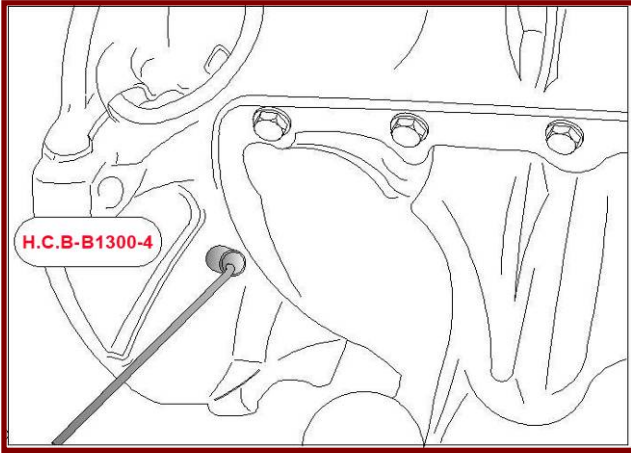

- Position crankshaft by ET1300A-4 when rotating crankshaft in central bolt.

※ **Note: Do not remove ET1300A-4 while servicing the engine.**

- When repairing exhaust camshaft, install ET1300A-1 on it and fix it by ET1300A-3.

- Install ET1300A-2 to cylinder head cover, then fasten with ET1300A-3-1. Put ET1300A-1 on intake camshaft, and fixed tool by ET1300A-3.

- Applications: MINI COOPER (N12/N14) 2007 R55
MINI COOPER (N12/N14) 2006~2007 R56