

ET1201A

BMW (X5) TRANSMISSION RUBBER MOUNT BUSH EXTRACTOR / INSTALLER

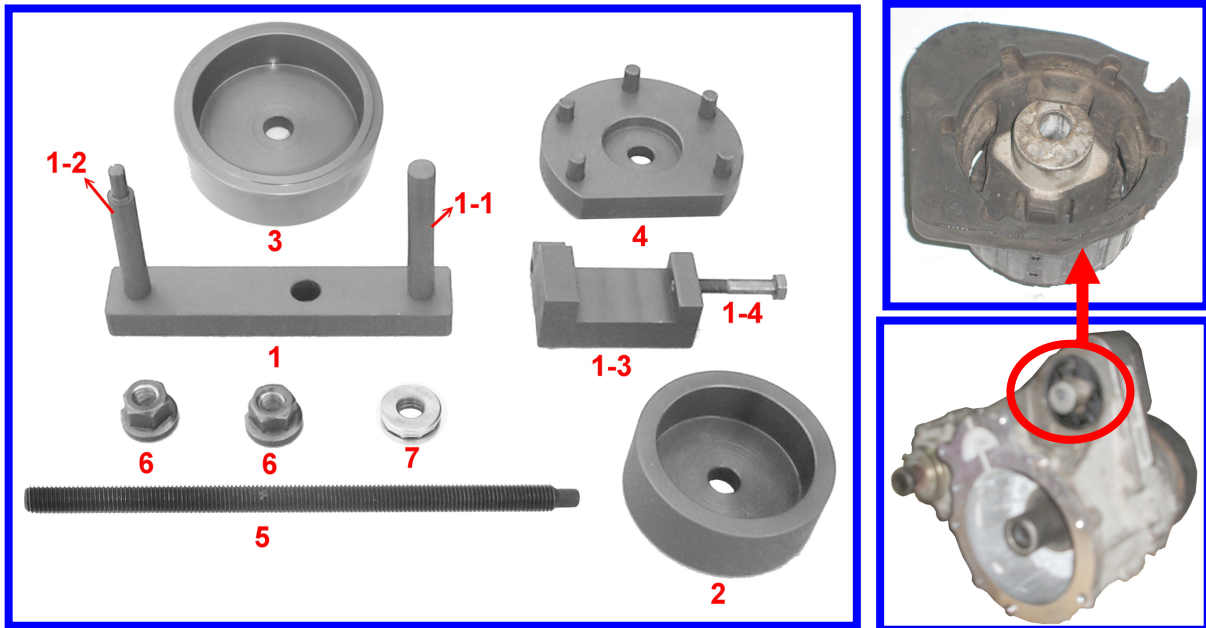

The Illustration for Removal:

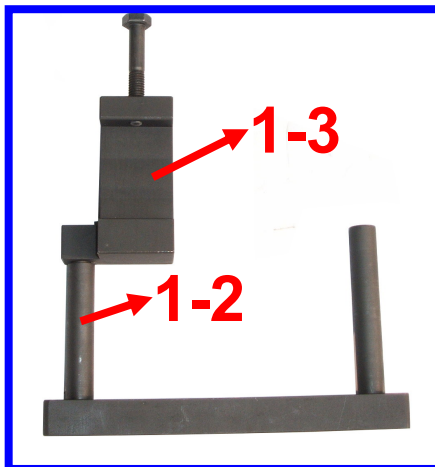

Picture 1

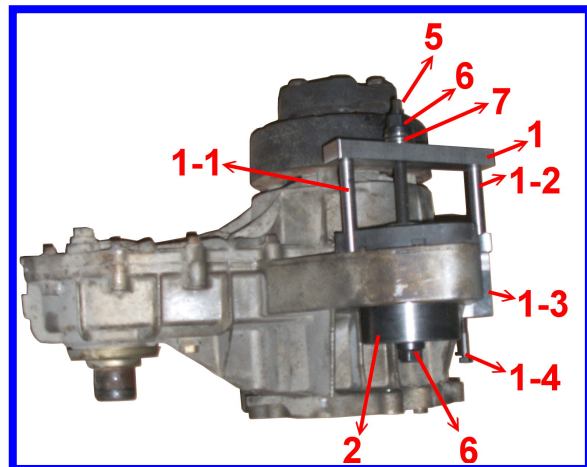

Picture 2

- Step 1: Put accessory No. 1-3 into 1-2. Please refer to the removal illustration picture 1 for guidance.
- Step 2: Make sure to clip the accessory No. 1-3 to the essence of the transmission, then put the accessory 1-1 into the outer breach of rubber mount to enable the central hole of accessory 1 and rubber mount to keep on a straight line. Then insert the accessory No. 5.
- Step 3: Install the bearing and nut on the both sides of accessory No. 5 after adjusting 1-4 and tightening 1-3.
- Step 4: To extract according to picture 2.

The Illustration for Install

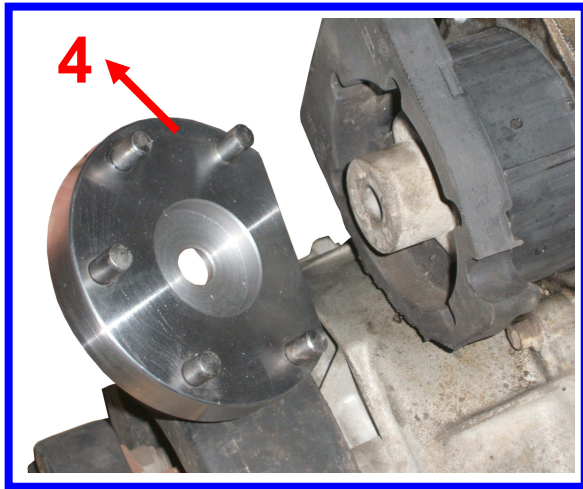

Picture 1

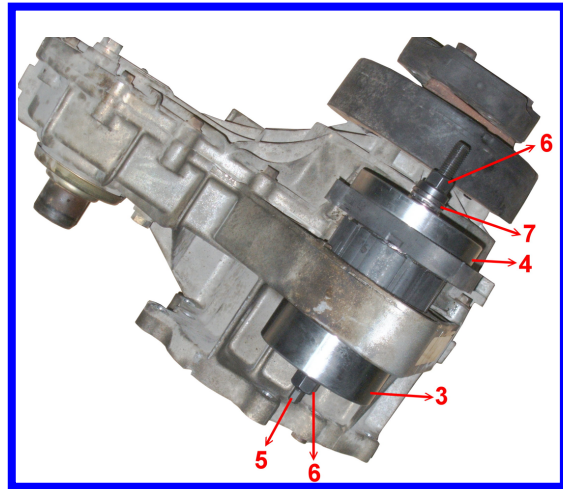

Picture 2

Step 1: Insert the locking pin of accessory No. 4 into the inner hole of rubber mount. Please refer to the install illustration picture 1 for guidance.

Step 2: To complete the installation according to picture 2.

■ **Applicable: BMW (X5, 3000c.c.) before year 2003.**