

■ Application:

128i. E82 (07-08), 130i. E81/E87 (05-08), 135iS. E82 (07-08), 323i. E90/91/92/93 (04-08), 325i/xi. E90/91/92/93 (04-08), 328i/xi. E90/91/92/93 (04-08), 330i/xi. E90/91/92/93 (04-08), 335i/xi. E90/91/92/93 (04-08), 523i/Li. E60/E61 (04-08), 525i/Li/xi. E60/61 (04-08), 528i/Li/xi. E60/61 (06-08), 530i/Li/xi E60/61 (05-08), 535i/xi E60/61 (06-08), 630i. E63/64 (04-08), 730i/Li. E65/66 (04-08), X3 2.5/ 3.0. E83 (06-08), X5 3.0. E70 (06-08), Z4 2.5/3.0. E85/86 (05-08)

■ Engine codeg:

N51/N52/N52K Valvetronic, Direct Injection, Non-Valvetronic N53/N54 and N55

■ BMW OEM Equiv:118 520/114 290/114 280/281/282/285/110 300/119 340/110 300

ET1188A-1 BMW (N51/N52) CAMSHAFT ALIGNMENT TOOL



- For locating camshaft in TDC position
- Application : BMW N51, N52

ET1188A-2 BMW (N51/N52) CAMSHAFT FIXING BASE



ET1188A-3

BMW (N51/N52/N52K/N53/N54) PLUG MANDREL

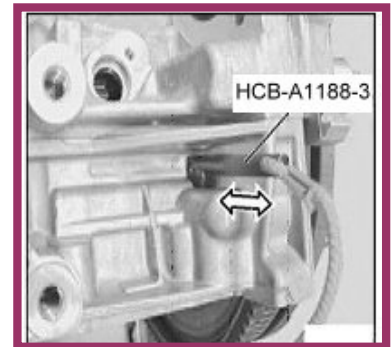

- For locking flywheel in TDC position on BMW N51, N52, N52K, N53, N54.
- Turns crankshaft to TDC position while central bolt moves.
- Put ET1188A-3 into calibration hole (arrow ahead) and fixed crankshaft.
- Attention:
 1. There is a big hole make use of TDC position nearby calibrate hole.
 2. When ET1188A-3 stayed in calibrate hole and locked flywheel, it is impossible to move engine through central bolt.

ET1188A-4

BMW (N53/N54) CAMSHAFT FIXING BASE



M6 x P1.0

- To align the camshaft.
- Applicable: BMW (N53/N54)



ET1136A-5

BMW (N40/N42/N45/ N46/N52/N62) CHAIN TENSIONER

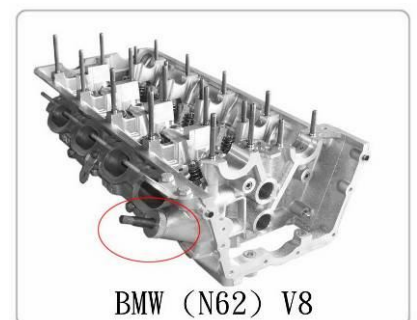

BMW (N62) V8

- For tension primary chain.
- Short format for late model new generation engines.
- Engine : N40, N42, N45, N46, N52, N62
- BMW V8 engine needs two sets of ET1136A-5 at the same time.

ET1188G-2&5

BMW (N55) CAMSHAFT FIXING BASE



- For disconnecting camshaft sensor gears.
- **BMW OEM Equiv: 114 290**

ET1188G-3

BMW (N55) PLUG MANDREL



- For locking flywheel in TDC position on BMW N51, N52, N52K, N53, N54, N55
- **BMW OEM Equiv: 110 300**

