

ET1181E

TRUCK SPRING PIN METAL BUSH REMOVAL/ INSTALLATION TOOL KIT

CE



VIDEO



**Optional:
E1181-20~24
For DAF(CF 85
truck lift axle
lug pin.**



**Optional: A3036 air pump
(3/8" ADAPTOR)**



DAF Part

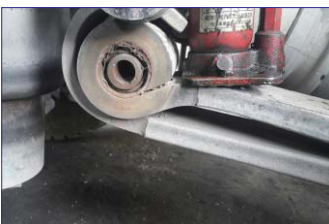

Renault (370)



**Optional: no. 20~24
For DAF (CF 85) truck lift
axle lug pin.**

IMPORTANT: READ THESE INSTRUCTIONS CAREFULLY.

- ⊗ Warning! Ensure Health and Safety, local authority and general work shop practice regulations are adhered to when using tools.
- ⊗ DO NOT use tool if damaged.
- ⊗ Maintain tool in good and clean condition for best and safest performance.
- ⊗ WARNING! The warnings, caution and instructions referred to in this manual cannot cover all possible conditions and situations that may occur. It must be understood that common sense and caution are factors which cannot be built into this product, but must be applied by the operator.

1. Kit Specification & Application

2-1VOLVO FM12 Spring Eye Bush Replacement

2-2RENAULT (430/450/460) Spring Eye Bush Replacement

2-3MAN-TGA (410/414/460) Spring Eye Bush Replacement

ET1181E**TRUCK SPRING PIN METAL BUSH REMOVAL/
INSTALLATION TOOL KIT****1. Kit Specification & Application**

No.	Description	Specification	Weight(g)	Q'ty	Remark
1	Hydraulic Ram	12tons (3/8"adaptor)	6,132	1	2 3/4"-16 UNC
2	Tube	φ 90x166L	2,628	1	
3	Extraction ring(1)	D φ 108 xd φ 74x20L	590	1	MAN-TGA(410/414/460) RENAULT(430/450/460)
4	Extraction ring(2)	D φ 108 xd φ 64x20L	682	1	VOLVO FM12
5	Extraction block(1)	φ 66x35LxH26	298	1	MAN-TGA(410/414/460)
6	Extraction block(2)	φ 59x34LxH26	248	1	RENAULT(430/450/460)
7	Extraction block(3)	φ 49x34LxH26	188	1	VOLVO FM12
8	Clamp body	D φ 143x d φ 90x54L	3,080	1	
8-1	Screw	M6xP1.0x25L	8	2	
8-2	Screw	M12xP1.75x80L	74	4	
8-3	Nut	M12xP1.75x18LxH19	38	4	
8-4	Fix ring	φ 20x φ 12.3x18L	28	4	
8-5	Washer	φ 20x φ 12.1x4L	6	4	
9	Clamp block(1)	D φ 90x d φ 68x54L	1,098	1	MAN-TGA(410/414/460)
10	Clamp block(2)	D φ 90x d φ 60x54L	1,424	1	RENAULT(430/450/460)
11	Clamp block(3)	D φ 90x d φ 51x54L	1,740	1	VOLVO FM12
12	Insertion block(1)	φ 78x35LxH26	516	1	VOLVO FM12
13	Insertion block(2)	φ 78x37LxH26	512	1	RENAULT(430/450/460)
14	Insertion block(3)	φ 98x36LxH26	732	1	MAN-TGA(410/414/460)
15	Insertion Ring(1)	φ 108x26L	928	1	MAN-TGA(410/414/460)
16	Insertion Ring(2)	φ 103x26L	860	1	RENAULT(430/450/460)
17	Insertion Ring(3)	φ 108x25L	1,040	1	VOLVO FM12
18	Insertion thread bolt	M16xP2.0x280LxH12	352	1	
19	Extraction thread bolt	M16xP2.0x195LxH12	244	1	

**VOLVO(FM12)BUSH****RENAULT
(430/450/460)BUSH****RENAULT(370)BUSH****MAN-TGA
(410/414/460)BUSH****DAF(LF/CF)**

- Most European trucks manufacturers design the special spring eye bush not to become loose. Therefore, they are hard to replace without special tools. We created this master kit to solve this problem. Save your time ,labour and money!

Applications: VOLVO(FM12),RENAULT(430/450/460),MAN-TGA (410/414/460), DAF(LF/CF)

For VOLVO (FM12)

Removal drawing

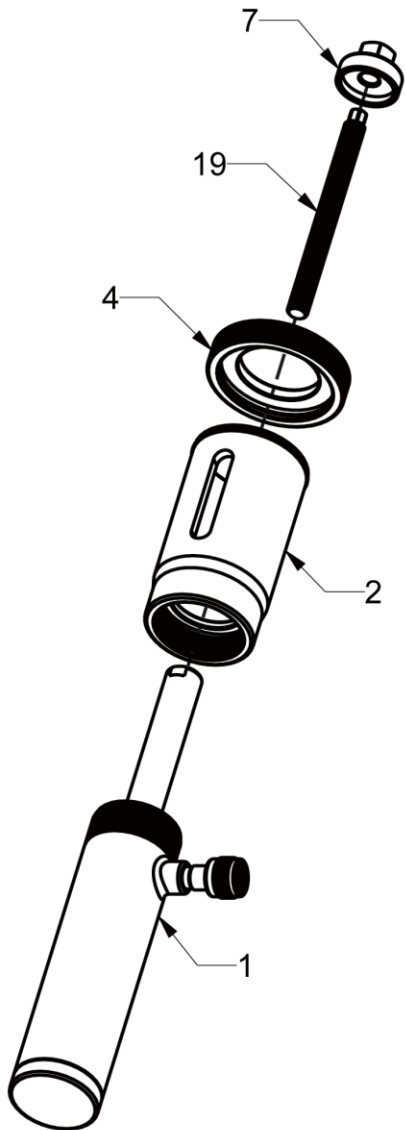

Assembly drawing

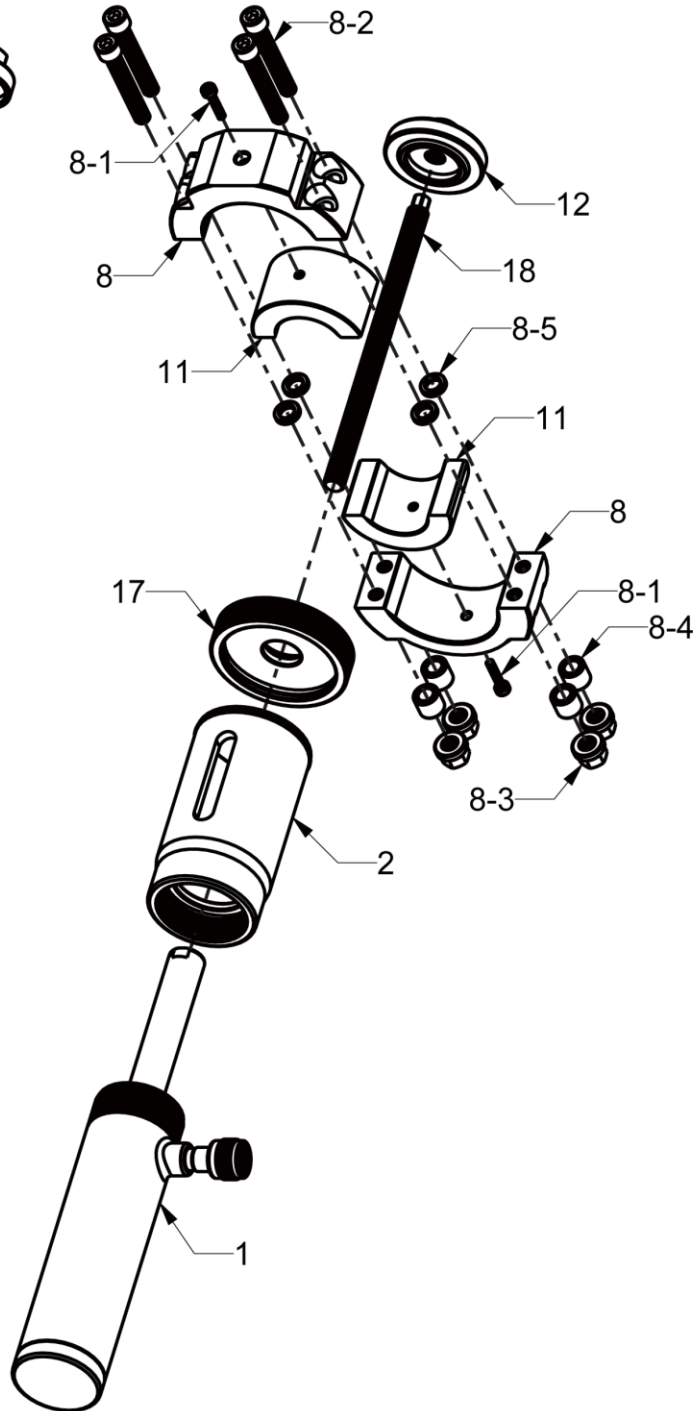

ET1181E

TRUCK SPRING PIN METAL BUSH REMOVAL/ INSTALLATION TOOL KIT

2-1VOLVO FM12 Spring Eye Bush Replacement:

Extraction

Refer to Fig 1. Assemble components as show.

1. Combined No. 1 ram with A3036
2. Insert No. 2 into No. 1.
3. Insert No. 4 into No. 2 front end.
4. Insert No. 19 screw into No. 1 ram.
5. Pass through the leaf spring bush.
6. Install and tighten No. 7
7. Press air pump to complete extraction.

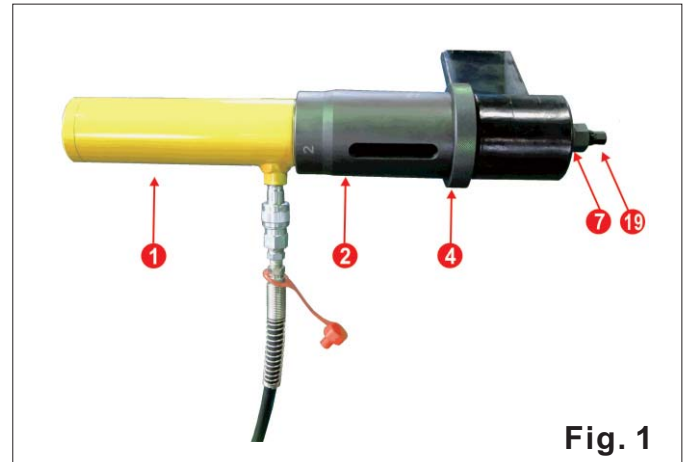

Fig. 1

Insertion:

Refer to Fig 2,3,4. Assemble components as show.

1. Put No. 11 compress kit into No. 8, then fix 8-1 screw .
Fit new bush to clamp of No. 8, gap of bush align to rift, tighten screw (Fig 2).
2. Combined No. 1 ram with A3036.
3. Insert No. 2 into No. 1
4. Insert No. 17 into No. 2 front end.
5. Insert No. 18 into No. 1 ram.
6. Make new bush pass through leaf spring and then fix No. 12
7. Press air pump until bush fitted to proper position, then remove No. 8.
8. Continue press air pump to fully fit the new bush.

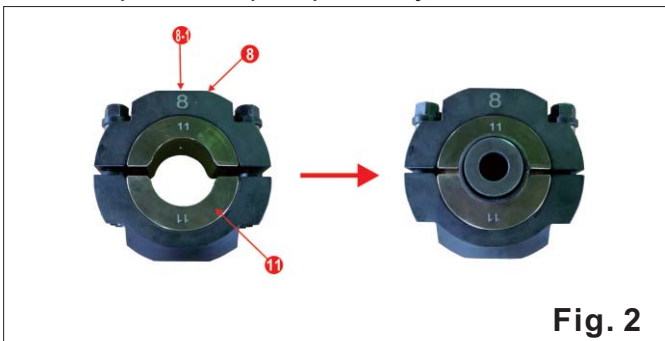

Fig. 2

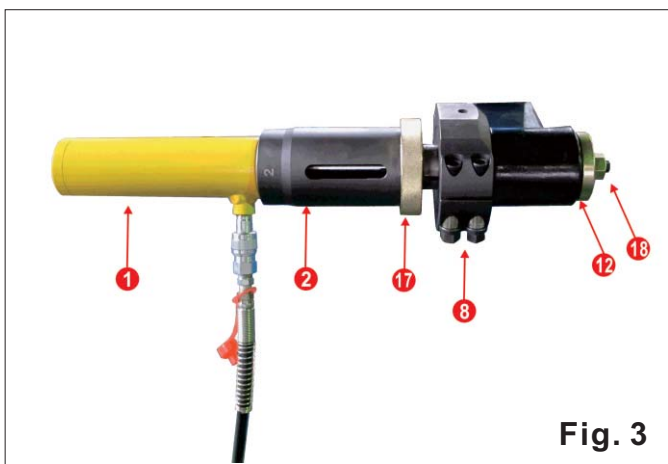

Fig. 3

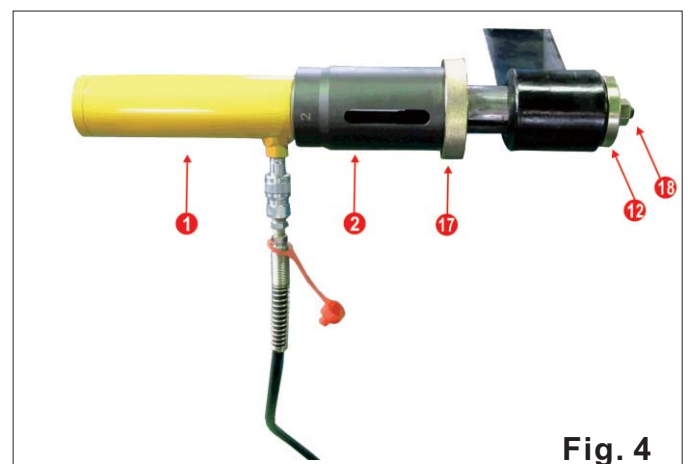
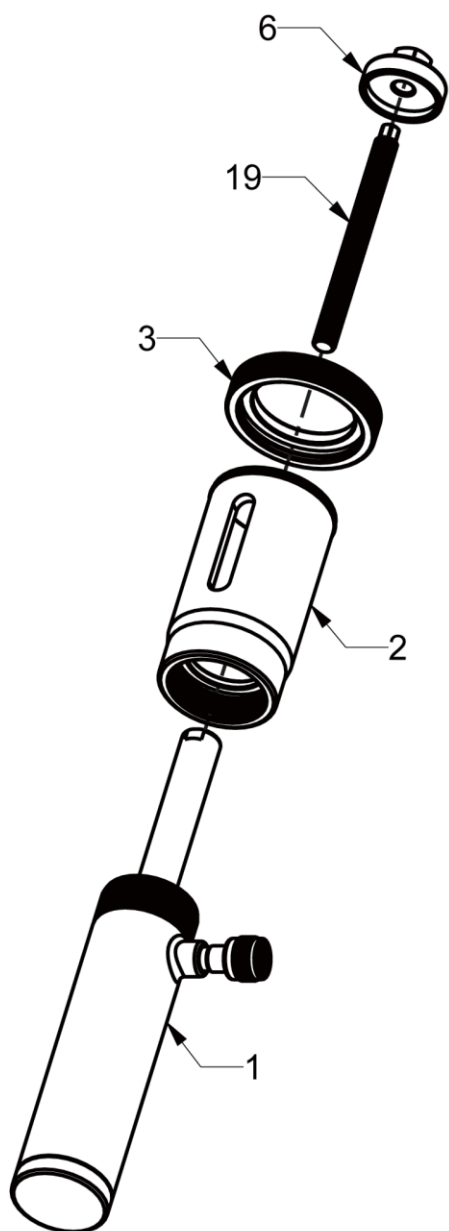

Fig. 4

For RENAULT (430),(450),(460)

Removal drawing



Assembly drawing

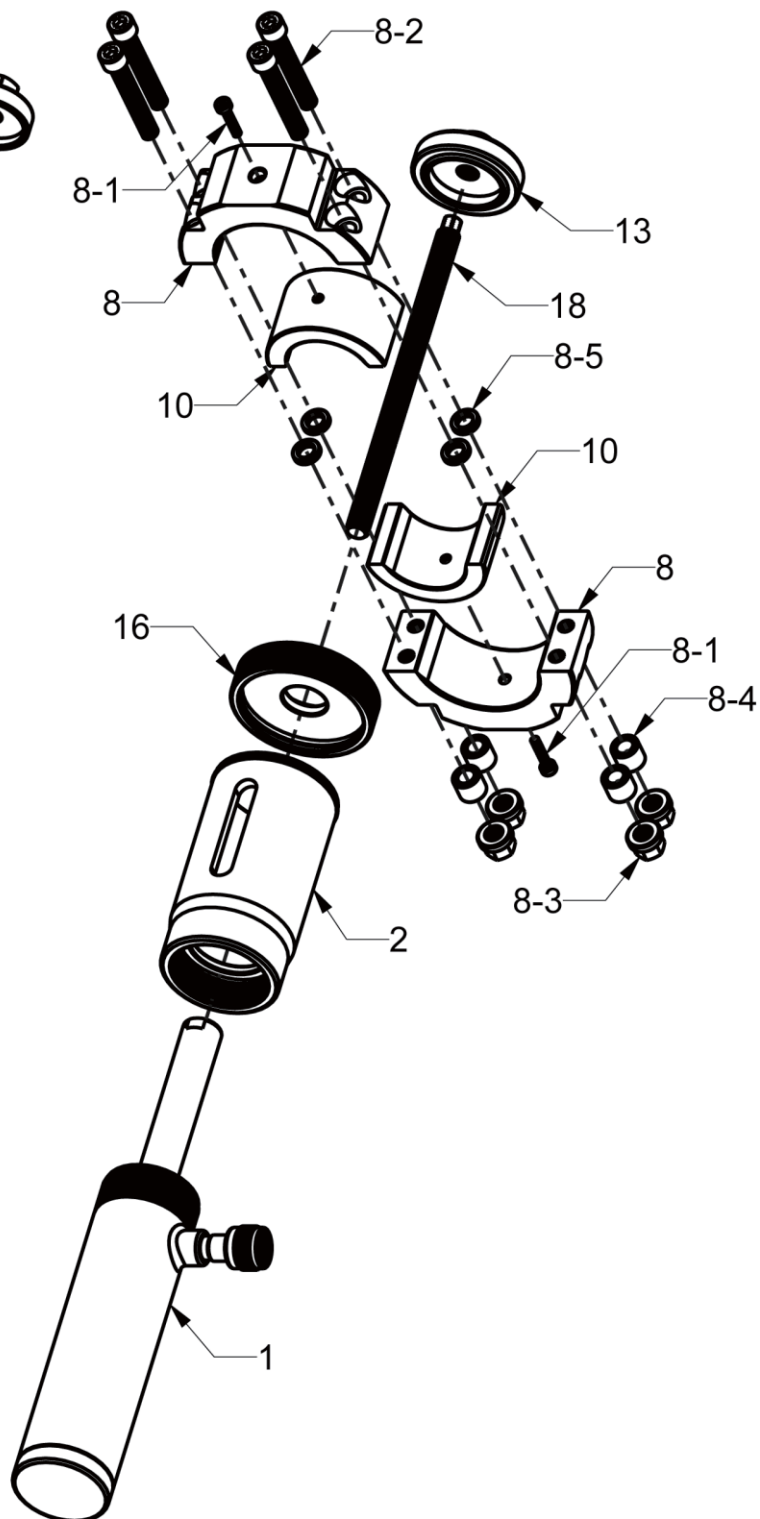

ET1181E

TRUCK SPRING PIN METAL BUSH REMOVAL/
INSTALLATION TOOL KIT

2-2RENAULT (430/450/460) Spring Eye Bush Replacement:

Extraction:

Refer to Fig 5. Assemble components as show.

1. Combined No.1 with A3036
2. Insert No.2 into No.1
3. Insert No.3 into No.2 front end.
4. Insert No.19 into No.1 ram.
5. Pass through the leaf spring bush
6. Install and tighten No.6
7. Press air pump to complete extraction.

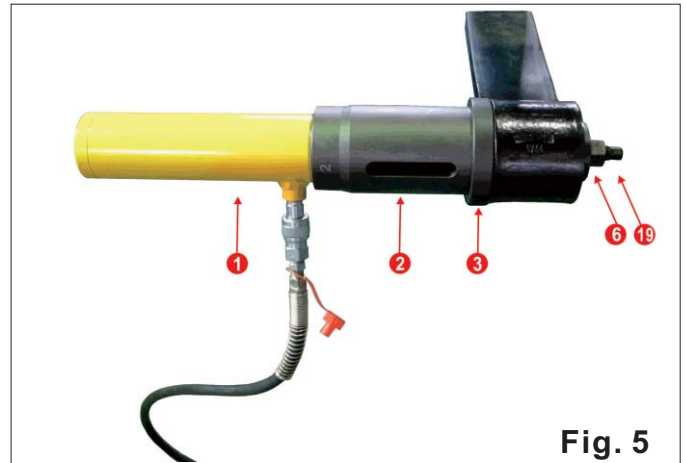

Insertion:

Refer to Fig 6,7,8. Assemble components as show.

1. Put No.10 compress kit into No.8, then fix 8-1 screw. Fit new bush to clamp of No.8, gap of bush align to rift, tighten screw (Fig 6).
2. Combined No.1 ram with A3036.
3. Insert No.2 into No.1
4. Insert No.16 into No.2 front end.
5. Insert No.18 into No.1 ram.
6. Make new bush pass through leaf spring and then fix No.13
7. Press air pump until bush fitted to proper position, then remove No.8.
8. Continue press air pump to fully fit the new bush.

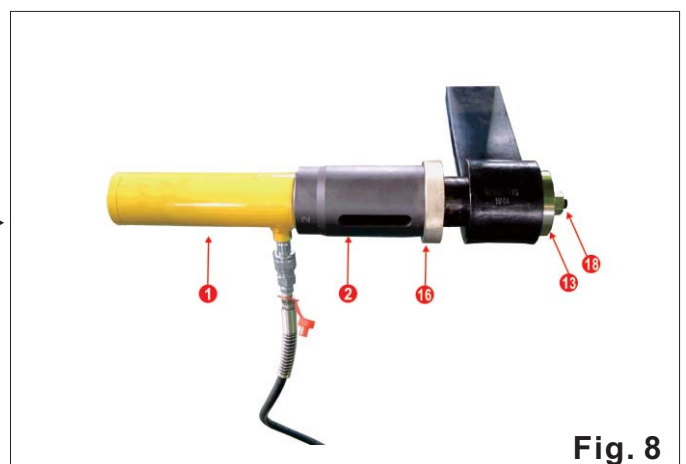
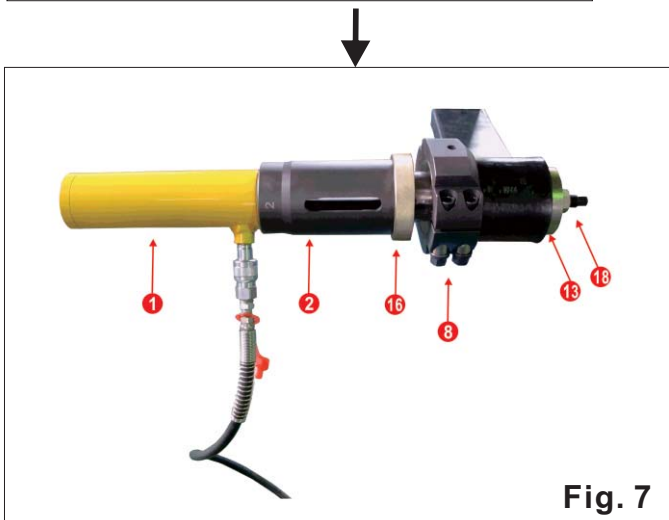
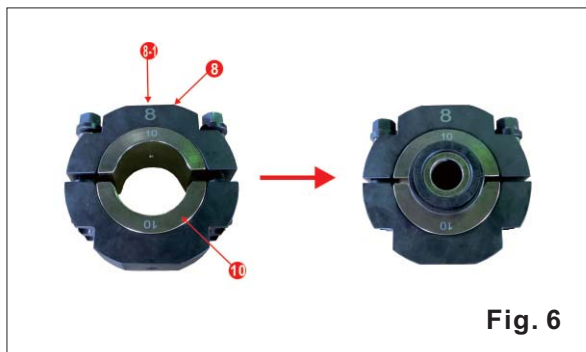

For MAN-TGA (410),(414),(460)

Removal drawing

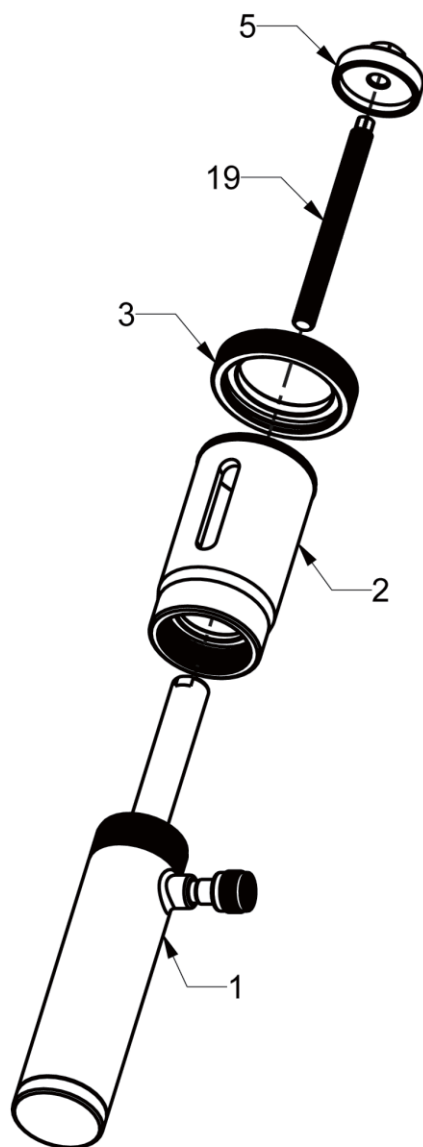

Assembly drawing

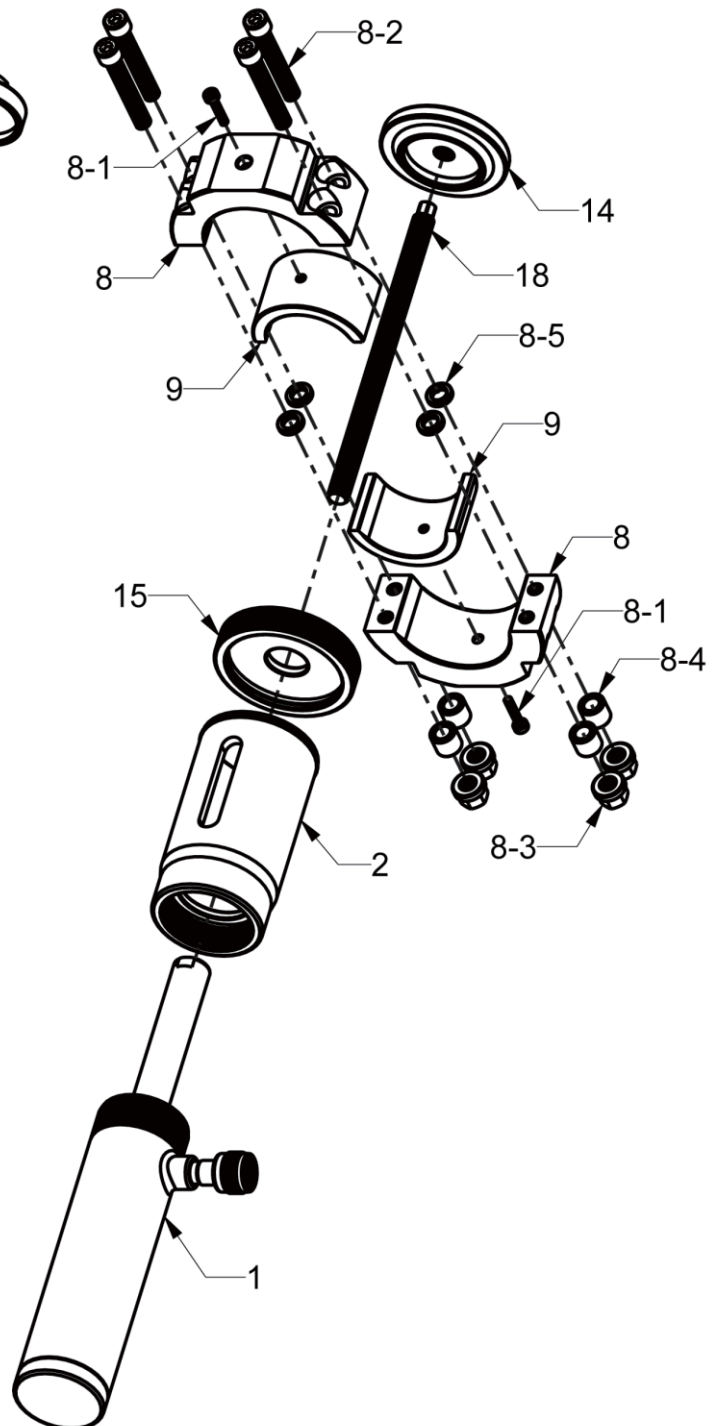

ET1181E

TRUCK SPRING PIN METAL BUSH REMOVAL/ INSTALLATION TOOL KIT

2-3MAN-TGA (410/414/460)Spring Eye Bush Replacement:

Extraction:

Refer to Fig 9. Assemble components as show.

1. Combined No.1 with A3036
2. Insert No.2 into No.1
3. Insert No.3 into No.2 front end.
4. Insert No.19 into No.1 ram.
5. Pass through the leaf spring bush
6. Install and tighten No.5
7. Press air pump to complete extraction.

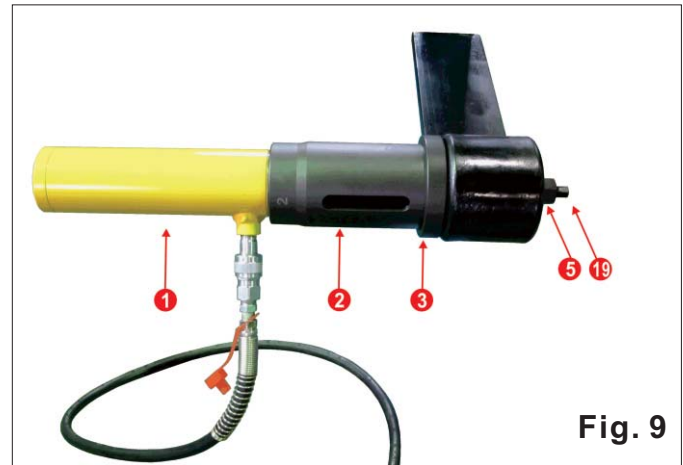

Insertion:

Refer to Fig 10,11,12. Assemble components as show.

1. Put No.9 compress kit into No.8, then fix 8-1 screw. Fit new bush to clamp of No.8, gap of bush align to rift, tighten screw (Fig 10).
2. Combined No.1 ram with A3036.
3. Insert No.2 into No.1
4. Insert No.15 into No.2 front end.
5. Insert No.18 into No.1 ram.
6. Make new bush pass through leaf spring and then fix No.14.
7. Press air pump until bush fitted to proper position, then remove No.8.
8. Continue press air pump to fully fit the new bush.

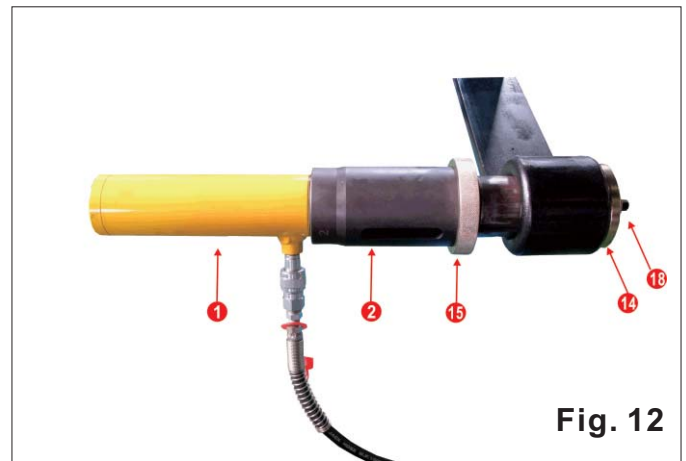
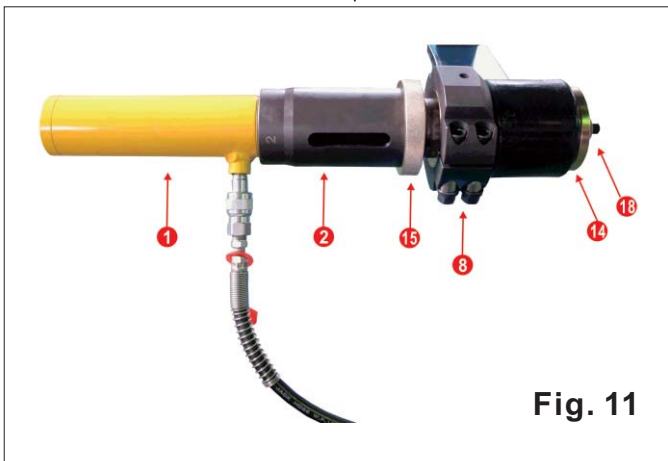
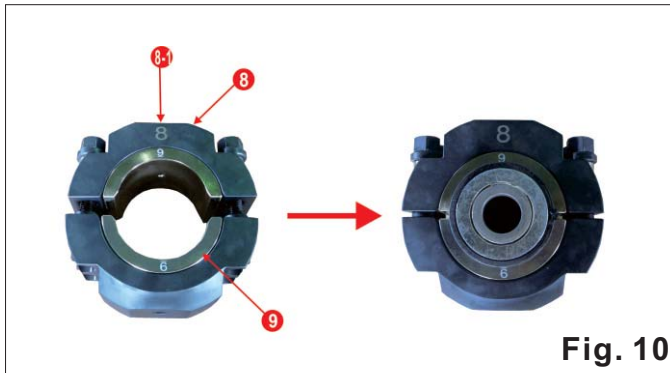

ET1181E

TRUCK SPRING PIN METAL BUSH REMOVAL/
INSTALLATION TOOL KIT

3-Optional no.20~24: For DAF (CF 85) truck lift axle lug pin



Optional no. 20~24

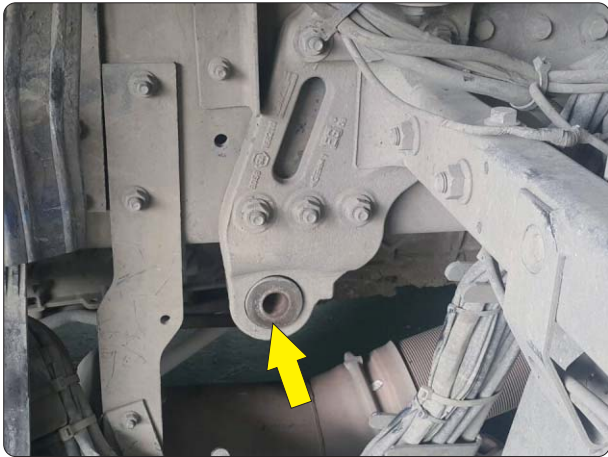

Removal of the lug pin.



Installation of the lug pin.



Narrow the new bush before install it.

