

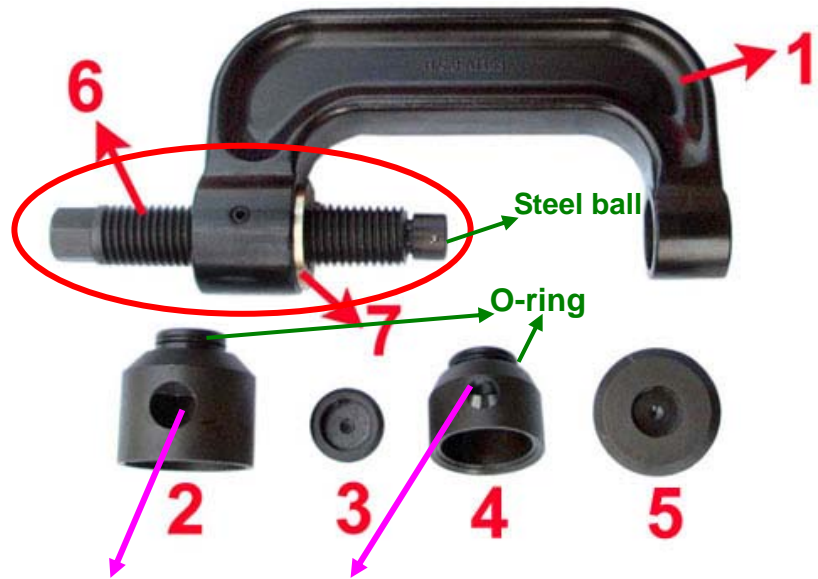

MERCEDES (W220 / W211 / W230) BALL-JOINT

REMOVER / INSTALLER PAT. M 333280

**** Special design for bolt, when the bolt is broken and you only just replace the bolt of c-clamp, not change the whole c-clamp set.**



Window for checking the repair process.

Steel ball and O-ring improve the assembly stability.

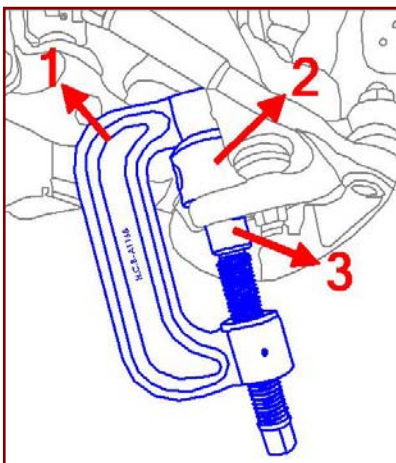

Extraction

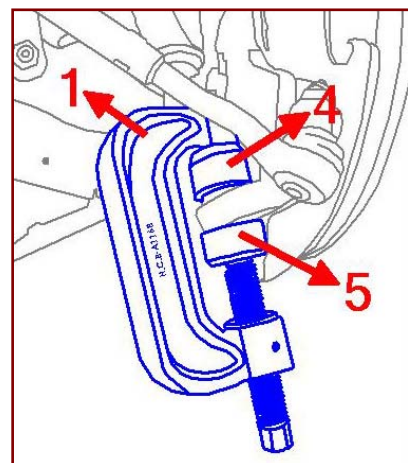

Installation

- The C-clamp is forged, it's material is SCM440 and hardness is HRC 38°-42°
- Designed for on car maintenance - a time saving tool!
- Special design to remove & install the ball joint without removing any parts.
- Applications: Mercedes W211 | W220 | W230