

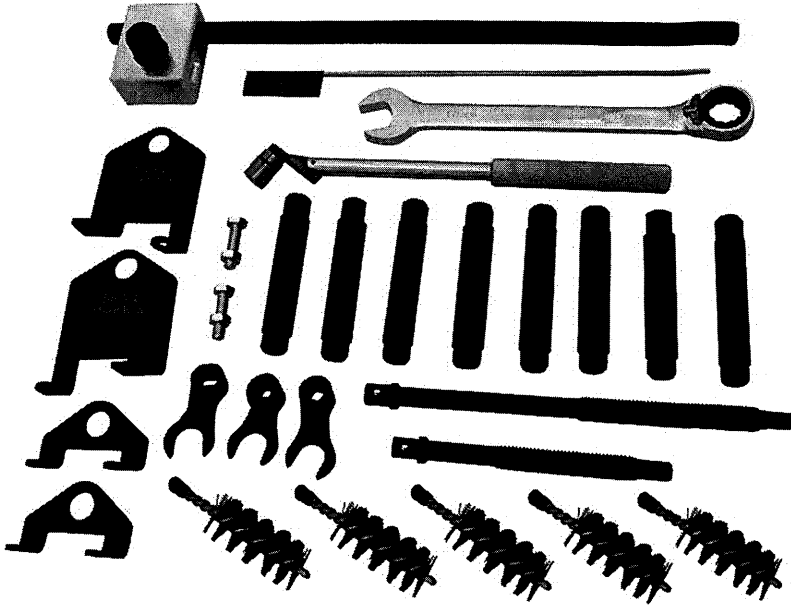

# ET0095

## VALVE STEM SEAL TOOL SET-BMW (N62 & N62-TU)

PAT.PEN.



### Applications:

2002-2005: BMW 745i & IL (E65 & E66)

2006-2008: BMW 750i & IL (E65 & E66)

2004-2006: BMW X5 4.4i/4.8is (E53)

2007-2010: BMW X5 4.8i (E70)

2004-2005: BMW 545i (E60)

2006-2010: BMW 550i (E60 & E61)

2004-2005: BMW 645Ci (E63 & E64)

2006-2010: BMW 650i (E63 & E64)

### \*\*Valve stem seal problem\*\*

Due to the old valve stem seal becomes hard over time and doesn't provide the proper seal between the seal and stem. This allows oil to pass through and enter the combustion chamber and exhaust. In addition, the old style seal does not seal on the inside to the guide, like the newer updated style seal. This creates an oil pocket underneath the seal that oil can accumulate in and make the problem worse.

### \*\*Solution\*\*

Perform the valve stem seal repair without removing the intake or exhaust cams by using this master valve stem seal tool kit. This tool kit saves you hours of labor!!

### \*\*Benefit\*\*

No need to remove intake or exhaust cams. No risk of setting the cam timing wrong. It also allows the car to pass Smog.

## Installation instructions :

This valve stem tool is intended for professional mechanics .It's a very involved job so make sure you're comfortable with taking the engine apart to this extent prior to beginning the job.

For the actual removal instructions of the valve covers Refer to TIS (Technical information System) its procedure # 11 12 005 for the left side and 11 12 006 for the right side.

5-series,6-series,7-series or the X5 have the same N62 engine. The procedure is the same the only difference is the layout of the engine bay. The labor time to do this repair varies a little depending on the model vehicle.

**Before begin the actual job, here are the tools needed not included in this kit:**

- Leak down tester –so you don't put too much pressure into the cylinder and cause the engine to turn over by accident.
- Magnet of your choice.
- Needle nose pliers-fuel hose type is preferred for getting the valve stem seals off the guides.
- 27mm socket with a short extension –prefer a long handle ratchet because it makes it really easy to turn over the engine in front of the crankshaft.
- White Lithium grease or something similar
- Spark plug socket

### 1. Valve cover L & R Remove

Begin by removing the left and right side valve cover. In order to remove the valve covers, start by disconnecting the cam servo motor. Spin them until they disengage the gear on the inside. You can unbolt the flange that the servo motor mounts to from the valve cover. Undo the cam position sensor connector in the back and of course all the screws in the valve cover. Then, lift it straight up begin careful not to damage the cam position sensor.

Note: This is easier said than done with the engine in the car but take great care to lift straight up!Once the valve cover is off, you have the 4 spark plug tubes that you'll need to remove as well.

### 2. Cam oil line L & R Remove

Remove the cam oil line and oil line clips on L & R side.

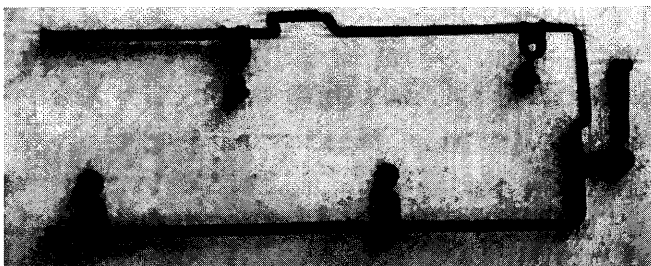

### 3. Cam position sensor L & R Remove

Remove the cam position sensor. This part only goes on one way so you don't have to worry about what position it's in.



4. Start by removing the spark plugs on the left and right side. Install the 8 spark plug / TDC Tool on all 8 cylinders. There's a hole in the center of it where you can insert the TDC indicator that comes with the kit. The spark plug/TDC tool doesn't need to be super tight, just tighten by hand. They have a little hole in them so objects can't fall into the cylinder. This is very important. The hole allows air to go in and out of cylinder so it's easier to turn over the engine while doing the repair.

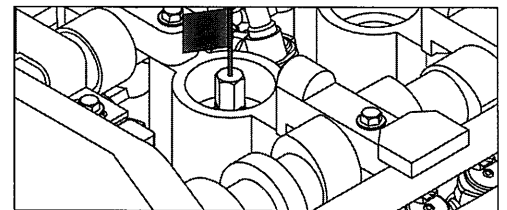
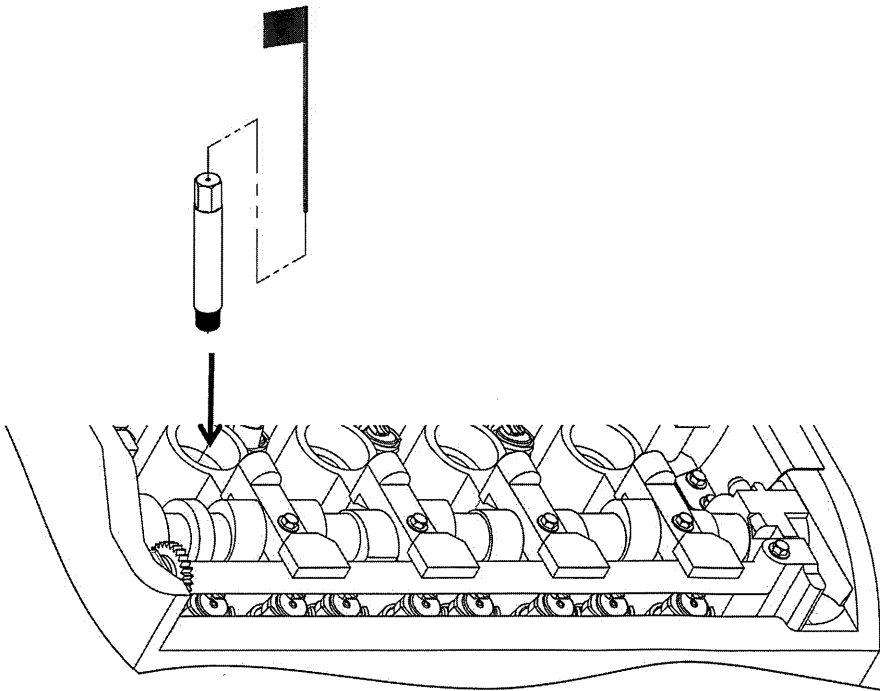

5. Install the brush plugs in oil return holes on the bank you are working on ,R side ( Bank 1 ) has 4 holes and L side ( Bank 2 ) has 5 holes. **The Brush plugs are very important** in case you accidentally drop a keeper the Brush plugs will prevent it from falling all the way down into the oil pan.



## 6. Install Intake and Exhaust plates

Install intake plates as shown in picture on cam cap #2 & 4, Note plates are marked for location, when installing bolt (supplied in kit) on square leg of intake plate, make sure bolt has full thread engagement before tightening nut (BMW nut). **NOTE: Do not over tighten nuts.** Install exhaust plates with on Cam cap #3 & 5 WITH BMW nuts.

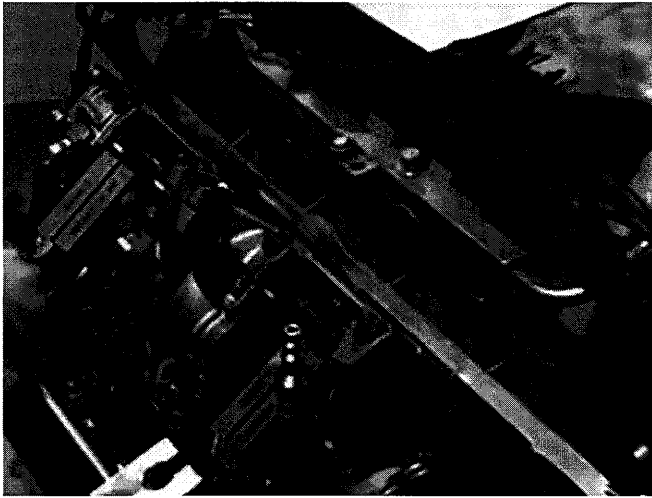

## 7. Cylinder on TDC in Compression

Insert TDC Indicator flag in hole of spark plug / TDC tool. Bring the cylinder to TDC in compression on the cylinder we are working on. Use a 27mm socket, short extension and preferably a long ratchet. Note that both intake and exhaust cam lobe is facing away from rocker arm. **Note :We recommend removing the ratchet after the engine is on TDC so that when you apply air to the cylinder, and if the engine turns over you don't break anything like radiator hoses or fittings in the front with the handle of the ratchet.** Remove spark plug / TDC tool install leak down tester hose.

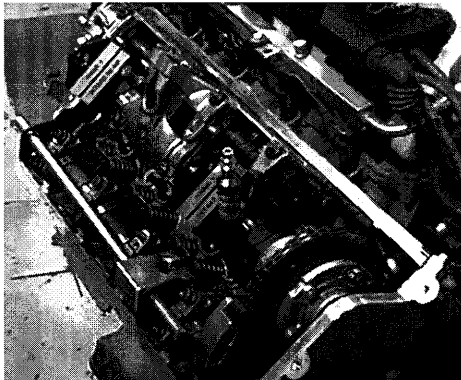

## 8. Chart

Reference the "chart" included in instructions. The compression lever foot is lasered : L =Left ,R=Right & S=Short

Note:the short lever (S) is used on the front ends where there is limited clearance.Refer to see what foot should be used.To avoid having to switch the cam holders from left to right every time, following firing order .Ex:working on Bank 1 Cylinder #1,the next cylinder in compression TDC will be Cylinder #4.(Firing order 1-5-4-8-6-3-7-2)

NOTE:One exception is on cylinder 2 because there's a block on the side of the cam shaft.Here you will have to have the engine a little before TDC or after TDC in order to be able to get the clearance you need to do the intake valve on this side.

## 9. Rocker arm remove

Start by inserting the compression rod and correct foot according to chart on the cylinder /valve you're working on, slide/rotate the fork of the foot underneath the rocker arm and onto the top of the valve spring retainer. **NOTE: Do not use force, if done correctly foot will go on without the use of force.**

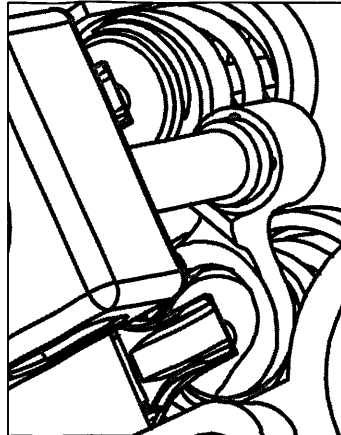
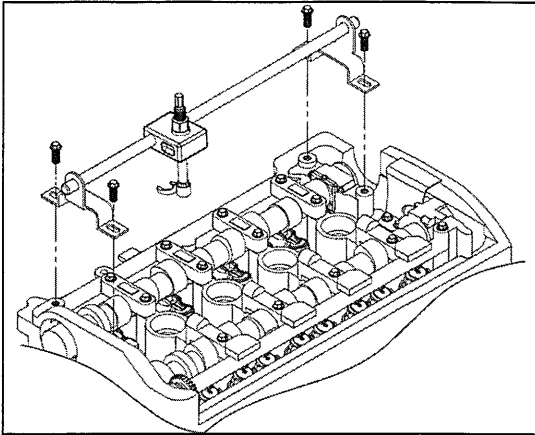

A. Turning the compression rod nice and easy until the spring compress app 1/4" or 6mm.

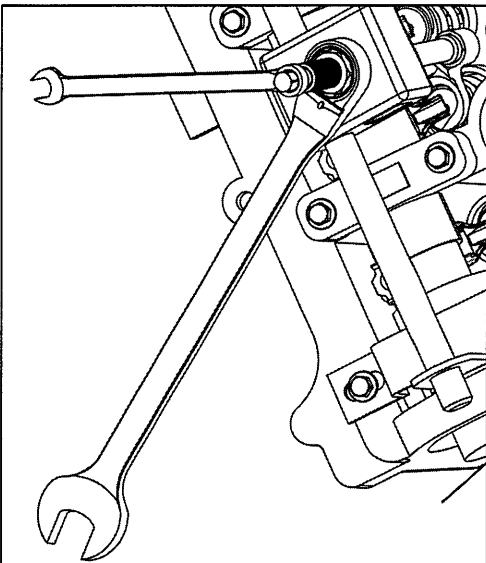

B. Now you can remove the rocker arm. Simply grab the rocker arm and lift up and snap it off the ball stud and pull it out.(you can use pliers) On the bottom of the rocker arm you can see the retainer clips that hold it onto the ball stud. When you're at the step you can also use this tool to replace bad lifters. The lifters just slide right out by hand. Next, flip the lever on the ratchet and reverse the rotation of the ratcheting wrench to allow the valve spring to extend and seat the valve.

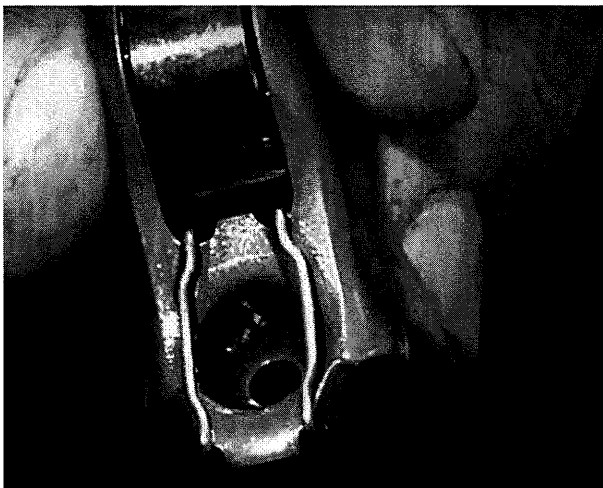

## 10. Valve Keepers, retainer and spring remove

Use leak down tester. Apply air pressure to the cylinder. You'll notice it has built pressure in the cylinder and it is keeping the valves closed. Once again, switch the rotation on the ratcheting wrench and this time compress the spring with air in the cylinder and the valve staying closed. Compress it far enough so that the keeper are fully exposed. With a magnet, remove the valve keepers. **.Note: Take great caution to not drop these into the engine.** Flip the lever on the ratcheting wrench and release the tension on the valve spring. Remove the lever and wrench and swing the assembly out of the way.

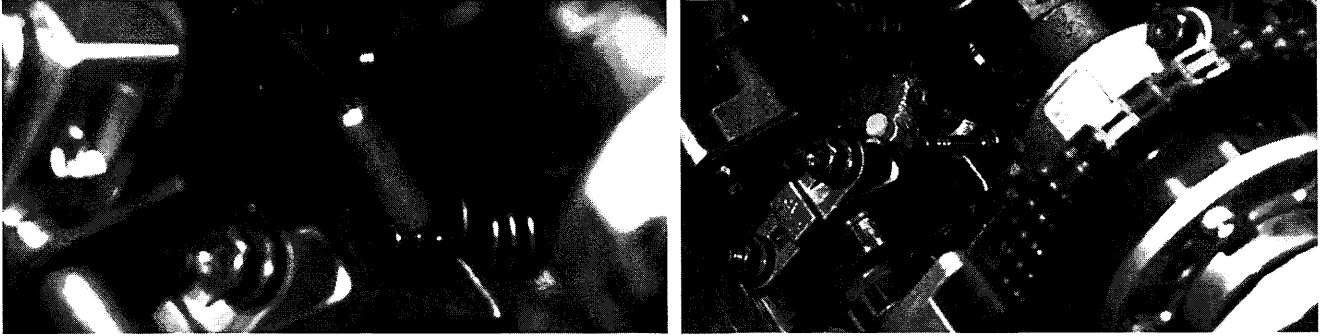

## 11. Valve stem seal remove

Remove the valve spring and retainer and if you have a pair of "fuel hose type pliers" it makes it much easier to remove the valve stem seal.



## 12. Valve stem seal install

The new valve stem seal kit comes with an installation sleeve. This installation sleeve gets installed on top of the valve. This is to prevent the new seal from getting nicked when going over the retainer grooves on the valve. Apply a little bit of grease to the new valve stem seal. With the sleeve installed, simply slide the new valve stem seal down over the valve and guide and push it on with the pliers. Remove the protective installation sleeve. Save this sleeve because you will need it to install the other valve stem seals.

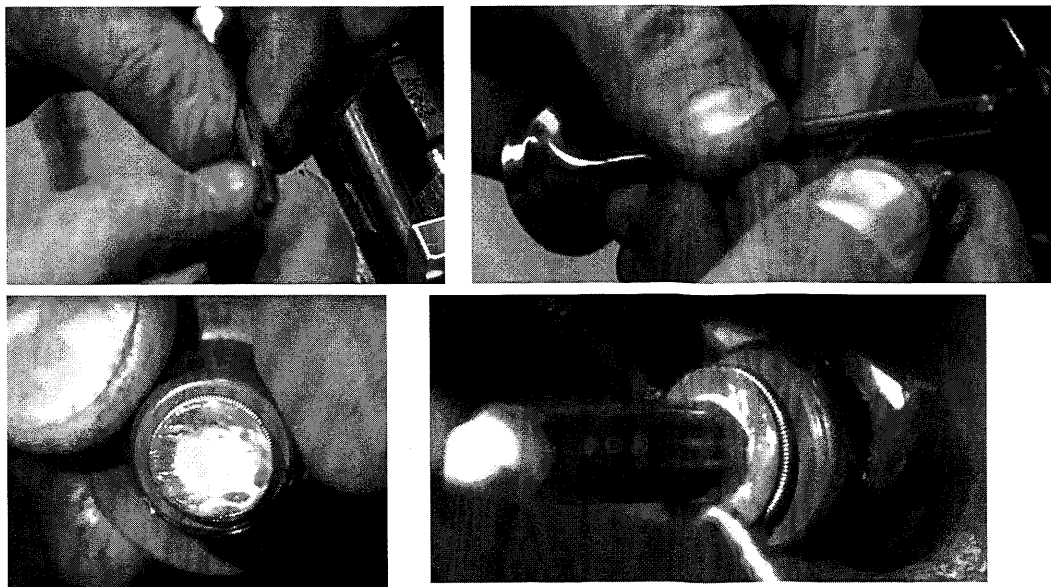

### 13. Spring & Retainer install

Install the spring and the retainer. Come back with the compression lever and slide the foot back onto the valve and begin compression by turning compression nut. While guiding the lever with the handle, compress the spring until the valve stem keeper grooves are fully exposed on the valves.



### 14. Valve keepers install with Tool

With the valve stem keeper installation tool, insert the keepers into the tool. Remember to have the fat side of the keeper facing into the tool. Dab it with a little grease. Insert the tool on top of the valve and push down. The keepers will automatically latch into place.

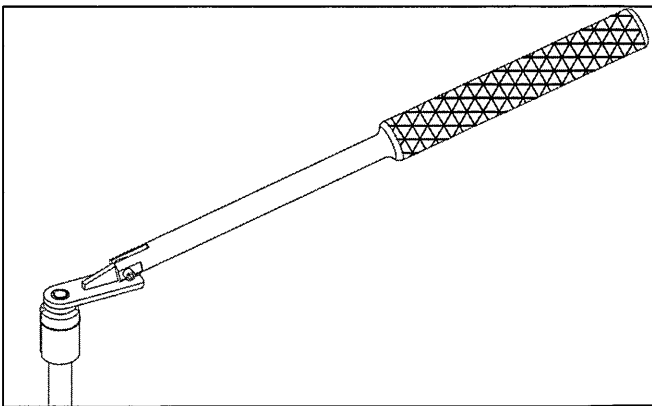
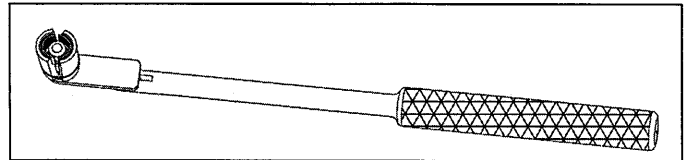
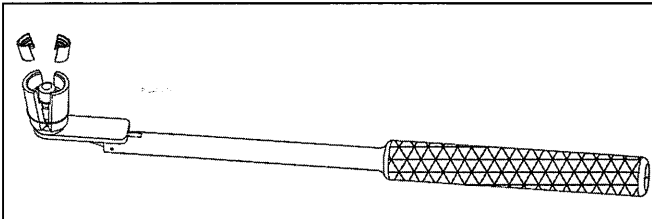

#### A. Valve keeper install without valve keeper tool

use screw driver with a little grease on the end to hold onto valve keeper, position valve keeper so it lines up with grooves in valve stem and insert so it sits in place ,repeat the process for the other side valve keeper, take great care not to knock the first valve keeper off during installing the second keeper.

15. Now switch the rotation of the lever on the ratcheting wrench and release the tension on the spring. Watch the keepers while doing this to insure that they don't get pushed off accidentally. Release the compressed air in the cylinder.



A. Rocker arm install

Compress the spring app 1/4" or 6mm so rocker arm can slide in place. If the spring stays up ,simply push it down by hand. You can now install the rocker arm by hand or with pliers. You should feel the rocker arm snap onto the lifter. Once it's on make sure the rocker arm is fully seated on top of the lifter and on top of the valve. Rotate the compression nut to release tension, slide /rotate the foot out from under the rocker arm.



16. These steps complete the replacement of 1 valve stem seals. Obviously there are 32 valve stem seals so repeat step 9 to 15. You will follow these steps 32 times. The same compression lever and rod is used on top for the intake. On the intake valves in the center of the engine you'll go through the hole in the intake cam tower. Here you'll take the foot and install it to the rod on the bottom by hand.

**REPEAT 32 TIMES!!**

17. In regards to the intake cam there's a very slight variation. The early cars have a spring assist on the intake ramp and to remove that spring just remove the torque screw. The spring can be released with a pair of pliers and pulled straight up and out. After that it's back to the same way as the later cars where you can access straight down with the short foot and the intake compression rod.





## Quick tips:

\*\* When doing the intake valves it has the variable lift lever on the intake that sits between the rocker arm and the cam shaft. This valve installation tool is designed to work on the intake with lever in place. It will have very little clearance but it will clear with only about 1/8" of an inch or 3mm. When you insert the tool it goes just under the pivoting arm.

\*\* With the keepers installed, remove the tool and release the valve the same way as the exhaust valve.

\*\* You don't have to remove the rocker lever but if you want to you can. It gives you a ton of room to work with when doing the repair but it's not necessary and just makes the job a little bit longer to do.

18. When the job is completed and before you reinstall the valve covers, as a precaution ,we recommend that you remove all the brushes, lay all the parts out on the counter and make sure you have all pieces included in the tool kit in front of you. This prevent you from possibly making a mistake and leaving items inside the engine.

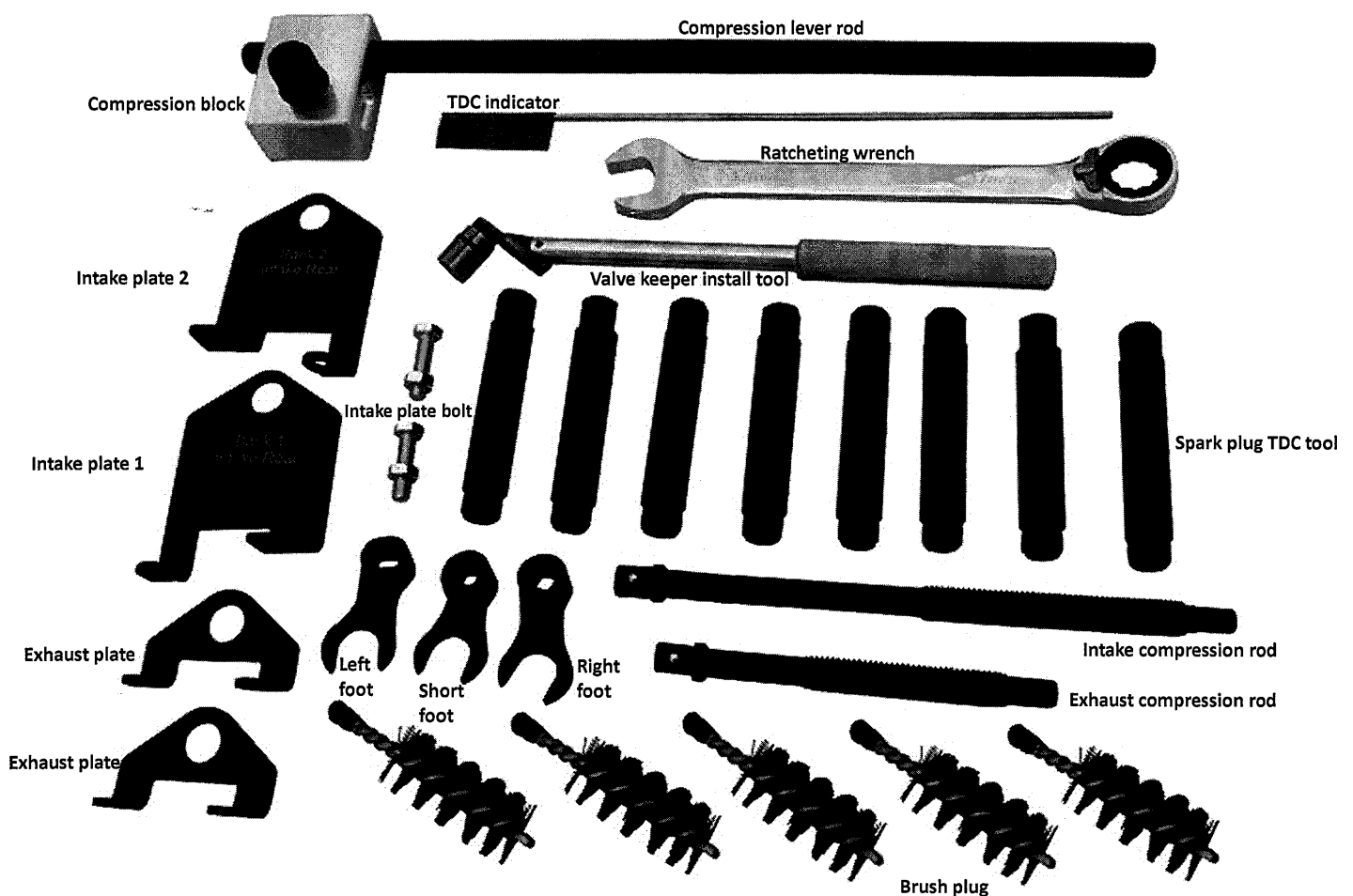

When job is completed, before installing valve covers, make sure you have all parts shown above.



**BANK 1**

Firing Order : 1-5-4-8-6-3-7-2

**BANK 2**

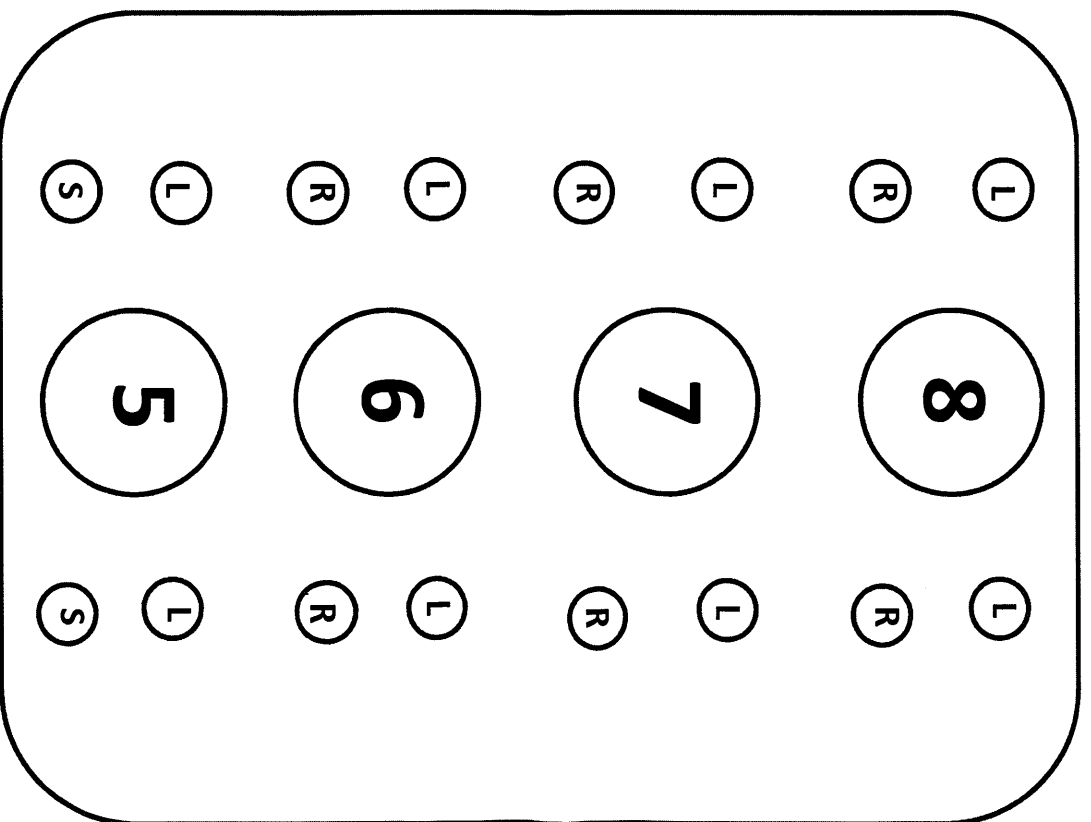
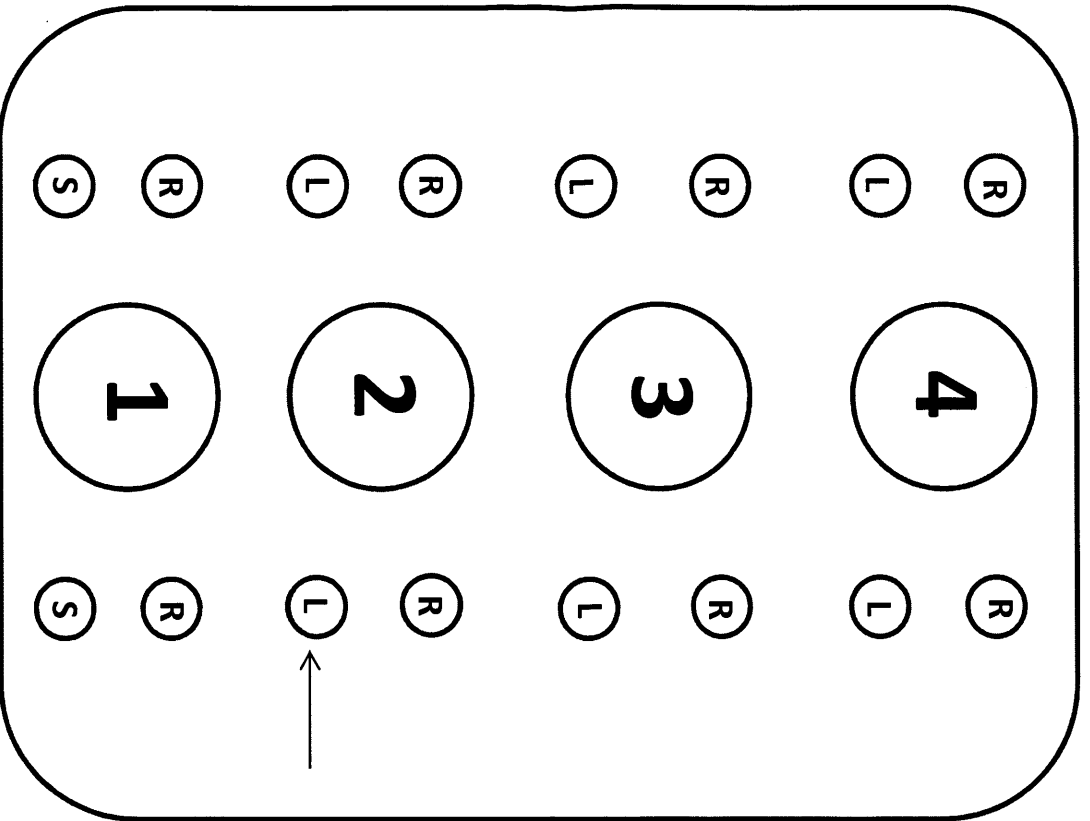

NOTE: Intake  
block interferes  
@ TDC. Turn  
slight past TDC.

L = Left  
R = Right  
S = Short

**Front of Vehicle**

