

E5850

Spot Mill

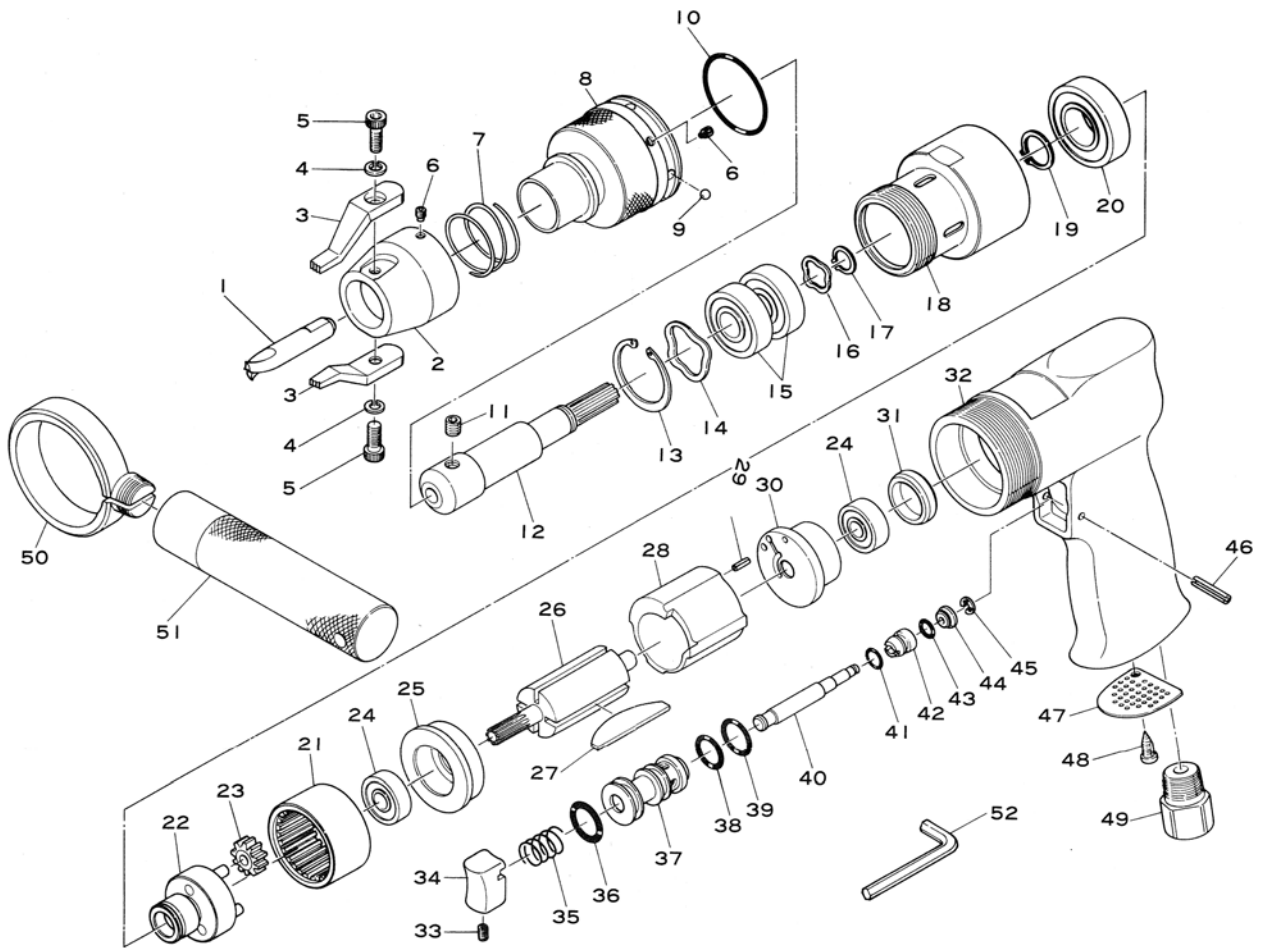

Ref. No.	Parts No.	Description	Q'ty	Ref. No.	Parts No.	Description	Q'ty
1	#271-17	Milling Cutter	1	27	#301-15	Rotor Blade	4
2	#1212-5	Guide Holder	1	28	#800-1	Cylinder	1
3	#1212-6	Guide	2	29	15-6	Roll Pin(1.5-6mm)	1
4	HSW-40	Washer	2	30	#300-4	Rear Plate	1
5	Z-M40-60	Cap Screw	2	31	#680-34	Bearing Cap	1
6	R2-M30-50	Set Screw	4	32	#210-1	Motor Housing	1
7	#1212-7	Spring	1	33	RM40-60	Set Screw	1
8	#1212-3	Adjust Ring	1	34	#120-18	Trigger	1
9	SB-30	Steel Ball	4	35	#120-31	Valve Spring	1
10	G-30	O-Ring	1	36	P-11	O-Ring	1
11	ROM50-50	Set Screw	1	37	#1212-22	Valve Body	1
12	#1212-4	Milling Cutter Chuck	1	38	P-10	O-Ring	1
13	JO-26	Retaining Ring	1	39	S-12	O-Ring	1
14	BWW-629	Wave Washer	1	40	#1212-23	Valve Stem	1
15	6000LLUC2	Ball Bearing	2	41	S-6	O-Ring	1
16	WW-100	Wave Washer	1	42	#1212-24	Main Valve	1
17	JS-10	Retaining Ring	1	43	S-5	O-Ring	1
18	#1212-1	Clamp Nut	1	44	#1212-25	2nd Valve	1
19	JS-15	Retaining Ring	1	45	JE-2	Retaining Ring	1
20	6002	Ball Bearing	1	46	25-20	Roll Pin(2.5-20mm)	1
21	#217-10	Internal Gear	1	47	#220-6	Deflector	1
22	#1212-2	Reduction Spindle incl. Pins	1	48	JBM40-80	Screw	1
23	#210-8	Planet Gear	3	49	#680-18	Inlet Bushing	1
24	626	Ball Bearing	2	50	#215-8-4	Clamp Ring	1
25	#210-11	Front Plate	1	51	#940-48	Handle	1
26	#210-13	Rotor	1	52	WRA-2.5	2.5mm Allen Wrench	1