

E4700B

Air Saw

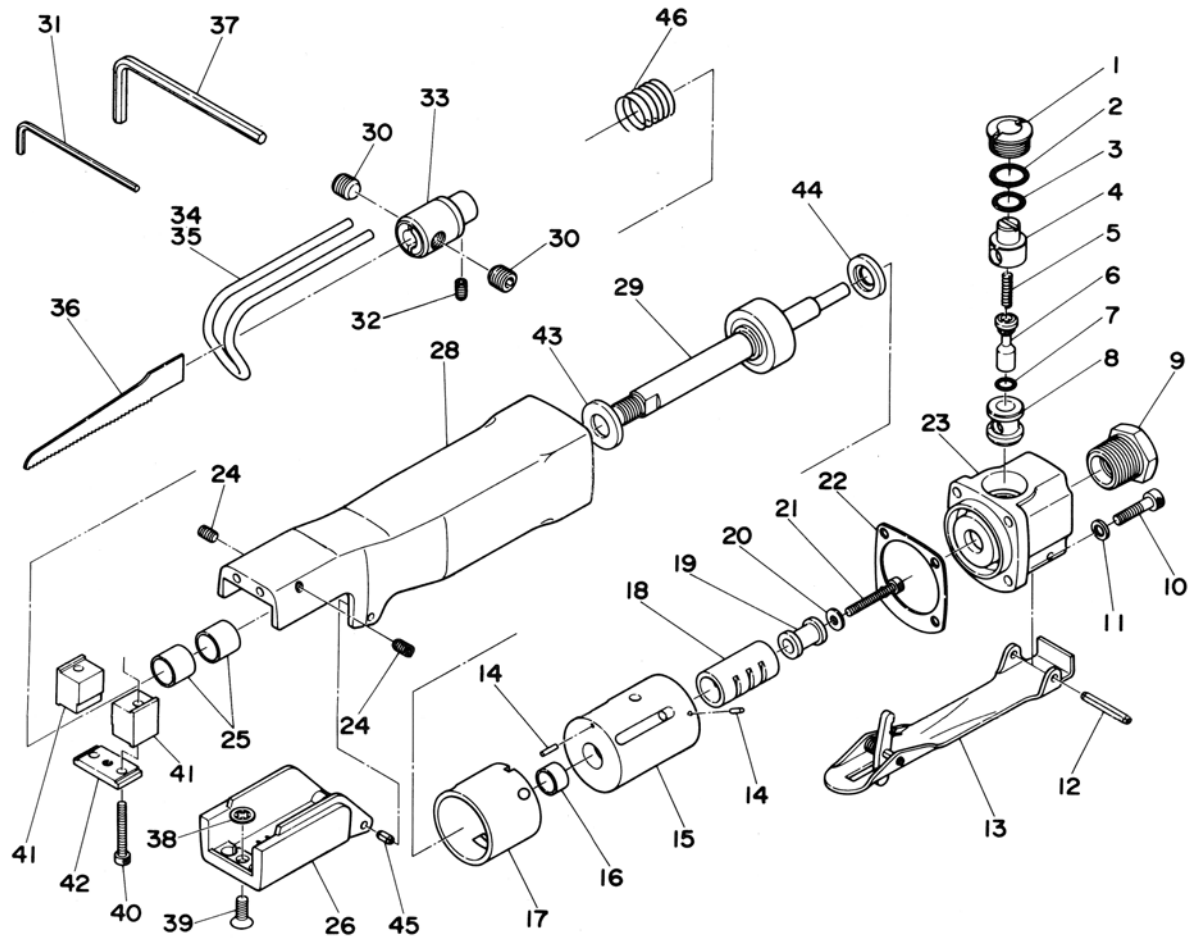

Ref. No.	Parts No.	Description	Q'ty	Ref. No.	Parts No.	Description	Q'ty
1	330-10	Valve Screw	1	24	ROM40-60	Set Screw	2
2	P-10	O-Ring	1	25	506-11	Bush	2
3	P-8	O-Ring	1	26	506-45A	Chuck Cover	1
4	330-8	Air Regulator	1	28	506-1D	Housing incl. Cover (660R-37)	1
5	350-7	Valve Spring	1	29	506-10A	Piston Rod Assy. incl. Piston, Spacer & Nut (506-14B, 506-15A, 506-16)	1
6	330-5	Valve Stem	1	30	ROM80-70	Set Screw	2
7	P-4	O-Ring	1	31	WRA-2	2mm Allen Wrench	1
8	330-4	Valve Bush	1	32	R3-M50-50	Set Screw	1
9	670-22	Inlet Bushing	1	33	506-3A	Blade Chuck	1
10	Z-832-190	Cap Screw	4	34	506-2L	Work Guide Long	1
11	HSW-40	Washer	4	35	506-2S	Work Guide Short	1
12	30-24	Roll Pin (3-24mm)	1	36	506-49A	Saw Blade	1
13	506-48A	Throttle Lever	1	37	WRA-4	4mm Allen Wrench	1
14	1500-68	Pin	2	38	GSE-3.5	Retaining Ring	1
15	506-19D	Valve Case	1	39	506-7	Screw	1
16	506-12	Bush	1	40	Z-M30-240	Cap Screw	2
17	506-17	Cylinder	1	41	506-46	Blade Guide	2
18	506-18	Valve Sleeve	1	42	506-52	Bridge	1
19	506-20	Actuate Valve	1	43	506-50D	Front Bumper	1
20	506-28	Washer	1	44	506-51D	Rear Bumper	1
21	Z-M30-220	Cap Screw	1	45	30-6	Roll Pin (3-6mm)	2
22	506-22D	Gasket	1	46	506-53	Spring	1
23	506-23D	Valve Block incl. Valve Bush (330-4)	1				