

E4110

Air Hammer

E4120

Air Hammer

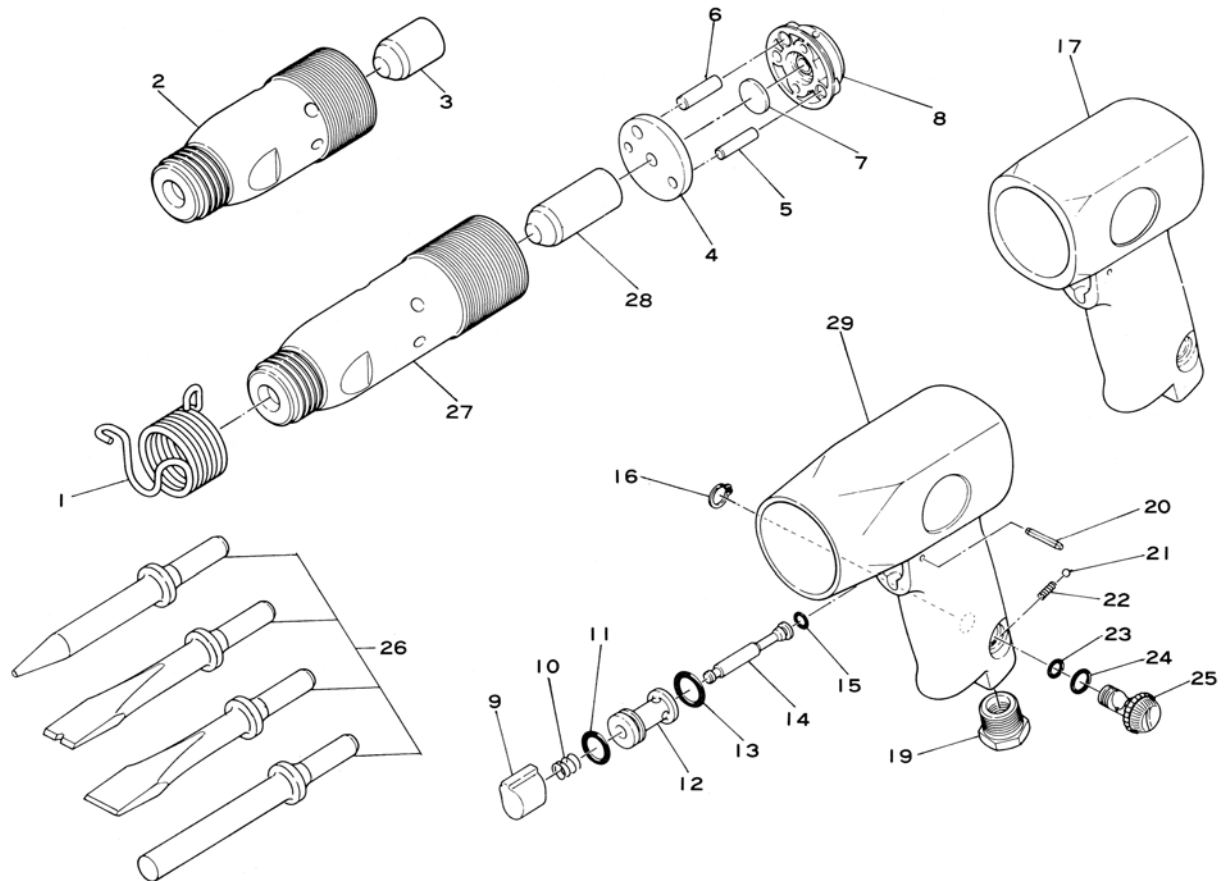

Ref. No.	Parts No.	Description	Q'ty	Ref. No.	Parts No.	Description	Q'ty
1	400-8	Retaining Spring	1	15	P-4	O-Ring	1
2	400-1	Cylinder for SI-4110	1	16	JS-9	Retaining Ring	1
3	400-2	Piston for SI-4110	1	17	400-11	Housing for SI-4110	1
4	400-4	Front Valve Case	1	19	670-22SC	Inlet Bushing incl. Screen (680-28A)	1
5	400-7	Dowel Pin (Small)	1	20	25-20	Roll Pin (2.5-20mm)	1
6	400-6	Dowel Pin (Big)	1	21	SB-1/8	Steel Ball	1
7	400-5	Valve Disc	1	22	450-45	Regulator Spring	1
8	400-3	Rear Valve Case	1	23	400-14A	O-Ring	1
9	170-20	Trigger	1	24	P-9	O-Ring	1
10	170-21	Valve Spring	1	25	400-12	Air Regulator	1
11	P-11	O-Ring	1	26	400-28	Chisel Set	1
12	170-19	Valve Bushing	1	★27	402-1	Cylinder for SI-4120	1
13	P-12	O-Ring	1	★28	402-2	Piston for SI-4120	1
14	170-18	Valve Stem	1	★29	402-11	Housing for SI-4120	1

★For E-4120

Printed in Japan
★★★★★ Sep. 1998