

E2050SG

High Speed Straight Grinder (55,000 RPM)

E2050AG

High Speed Straight Grinder (25,000 RPM)

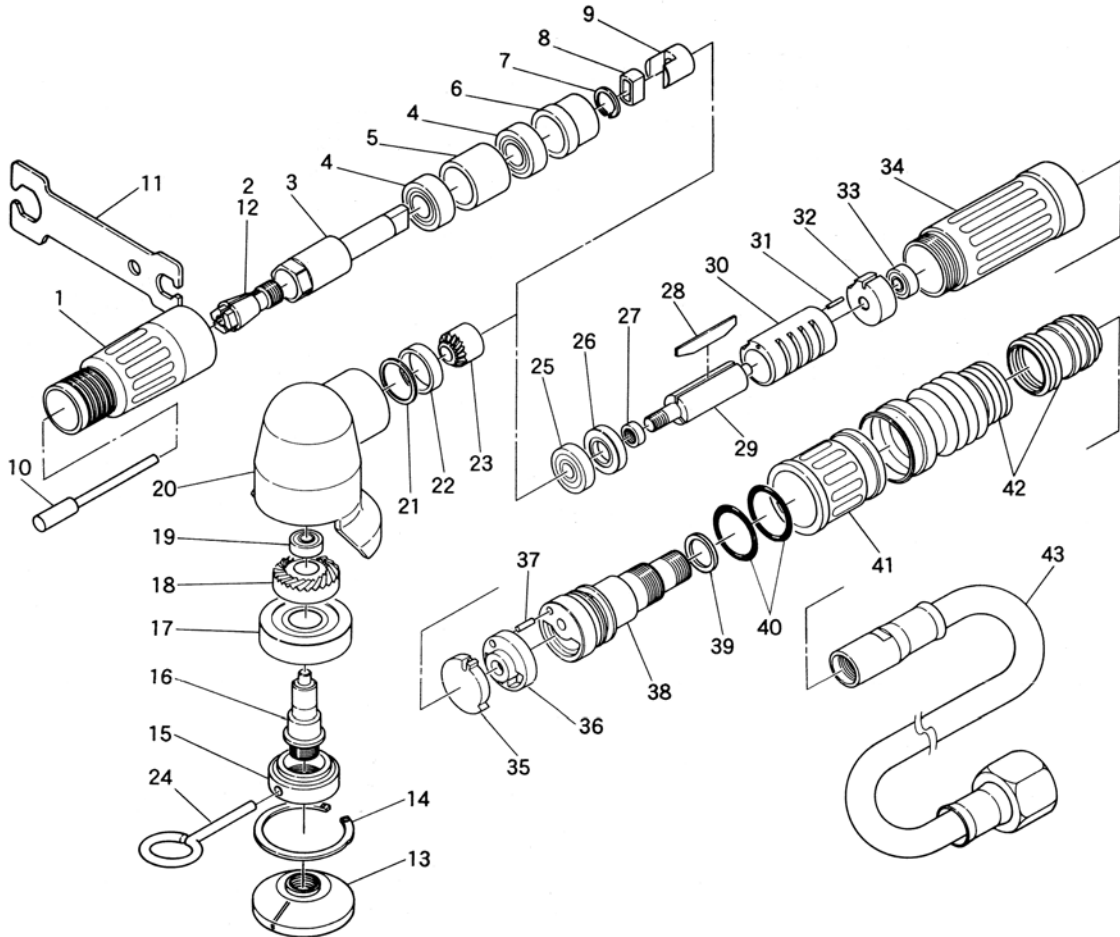

Ref. No.	Parts No.	Description	Q'ty	Ref. No.	Parts No.	Description	Q'ty
★1	340-1	Front Case	1	☆23	340-40	Pinion Gear	1
★2	340-2A	3mm Collet	1	☆24	340-53	Lock Pin	1
★3	340-3	Spindle	1				
★4	686-ZZ	Ball Bearing	2	25	604-ZZ	Ball Bearing	1
★5	340-6	Spindle Collar A	1	26	340-12	Front Plate	1
★6	340-8	Spindle Collar B	1	27	340-29	Rotor Collar	1
★7	GV-6	Retaining Ring	1	28	340-11	Rotor Blade	3
★8	340-4	Joint Cushion	1	29	340-10	Rotor	1
★9	340-9	Coupling	1	30	340-14	Cylinder	1
★10	340-55	5 φ mm Grindstone	1	31	340-16	Cylinder Pin	1
★11	340-27	Spanner Wrench (Hex 6x9mm)	2	32	340-15	Rear Plate	1
◆★12	340-2B	1/8" Collet		33	693-ZZ	Ball Bearing	1
				34	340-20	Motor Housing	1
☆13	340-57	30 φ mm Disc	1	35	340-17	Spacer	1
☆14	OV-22	Retaining Ring	1	36	340-18	Connector	1
☆15	340-45	Disc Receiver	1	37	1500-68	Pin	1
☆16	340-35	Spindle	1	38	340-21	Valve Body	1
☆17	608-ZZ	Ball Bearing	1	39	340-54	Washer	1
☆18	340-41	Bevel Gear	1	40	340-23	O-Ring	2
☆19	693-ZZ	Ball Bearing	1	41	340-24	Valve Ring	1
☆20	340-32	Angle Head	1	42	340-26	Exhaust Hose	1
☆21	340-22	Shim	1				
☆22	340-47	Pinion Collar	1	43	340-25	Wipe Hose Assy. incl. (340-25A, 340-25B, 340-25D)	1

☆For E-2050AG ◆Option
★For E-2050SG

Printed in Japan
★★★★Apr. 2000