

E2015A

Die Grinder 4,500 RPM

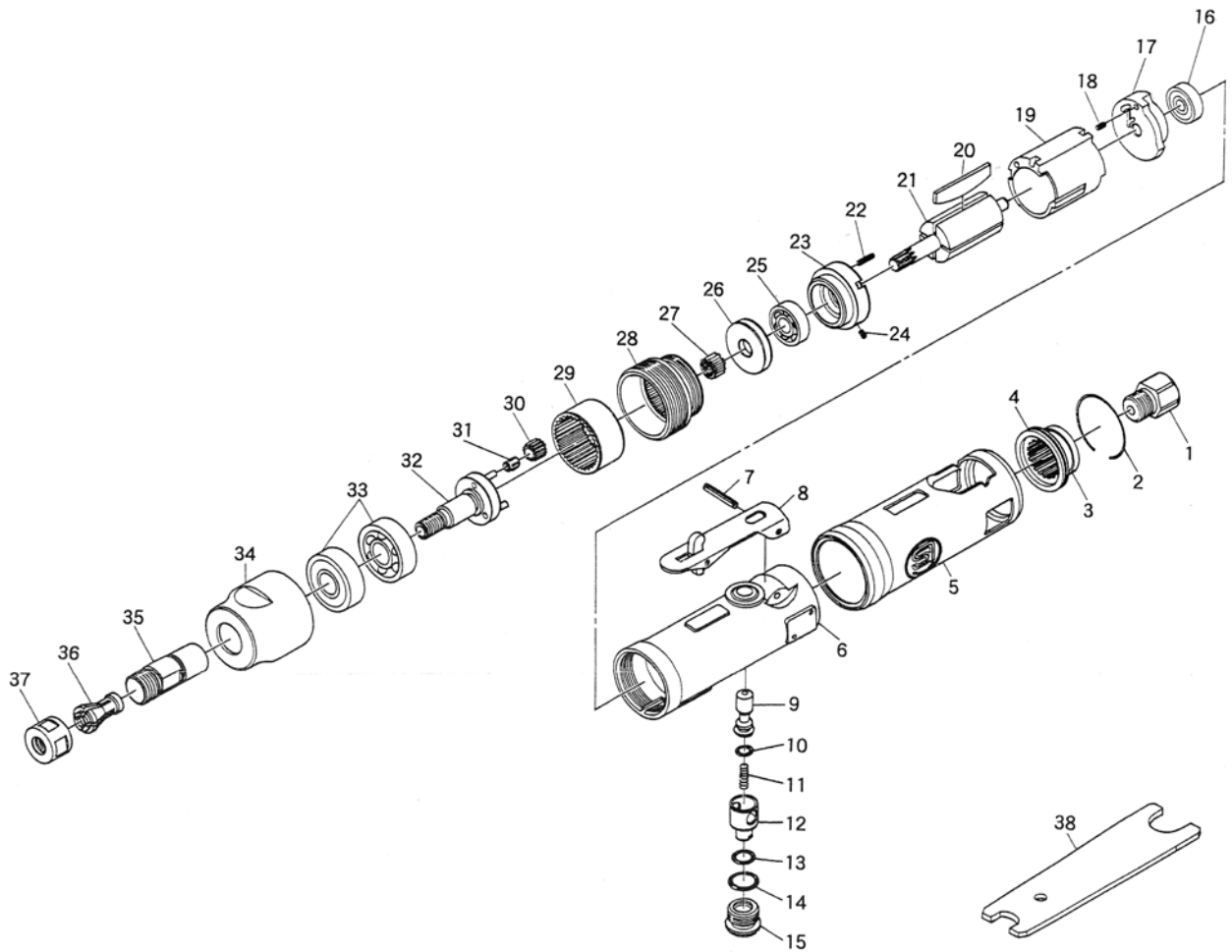

Ref. No.	Parts No.	Description	Q'ty	Ref. No.	Parts No.	Description	Q'ty
1	180-1SC	Inlet Bushing incl. Screen (680-28A)	1	20	350-16	Rotor Blade	4
2	620-30	Retaining Ring	1	21	270-45LA-1	Rotor	1
3	620-18	Deflector	1	22	20-10	Roll Pin (2-10mm)	1
4	620-28	O-Ring	1	23	270-45LA-2	Front Plate	1
5	892-2R	Housing Cover	1	24	25-4	Roll Pin (2.5-4mm)	1
6	892-1	Motor Housing incl. Bush (350-4)	1	25	608	Ball Bearing	1
7	30-24	Roll Pin (3-24mm)	1	26	270-45LA-4	Spacer	1
8	350-2L	Throttle Lever	1	27	1300-45C-1	Pinion Gear	1
9	350-5	Valve Stem	1	28	270-45LA-3	Motor Lock Ring	1
10	P-5	O-Ring	1	29	1300C-16	Internal Gear	1
11	350-7	Valve Spring	1	30	1300-45C-2	Planet Gear	3
12	350-8	Air Regulator	1	31	1300-45C-4	Cage incl. Pins (1300-45C4Ax5)	3
13	P-8	O-Ring	1	32	1300-45C-3	Spindle incl. Pins (3000-15-8x3)	1
14	P-11	O-Ring	1	33	6201-Z	Ball Bearing	2
15	350-10	Valve Screw	1	34	1300C-15	Clamp Nut	1
16	626-ZZ	Ball Bearing	1	35	130-15	Spindle	1
17	620-9	Rear Plate	1	36	330-19	6mm Collet	1
18	25-5	Roll Pin (2.5-5mm)	1	37	350-23	Collet Nut	1
19	680-1	Cylinder	1	38	350-28	Spanner Wrench (14x19mm)	2