

E2011S

Middle Die Grinder - Rear Exhaust

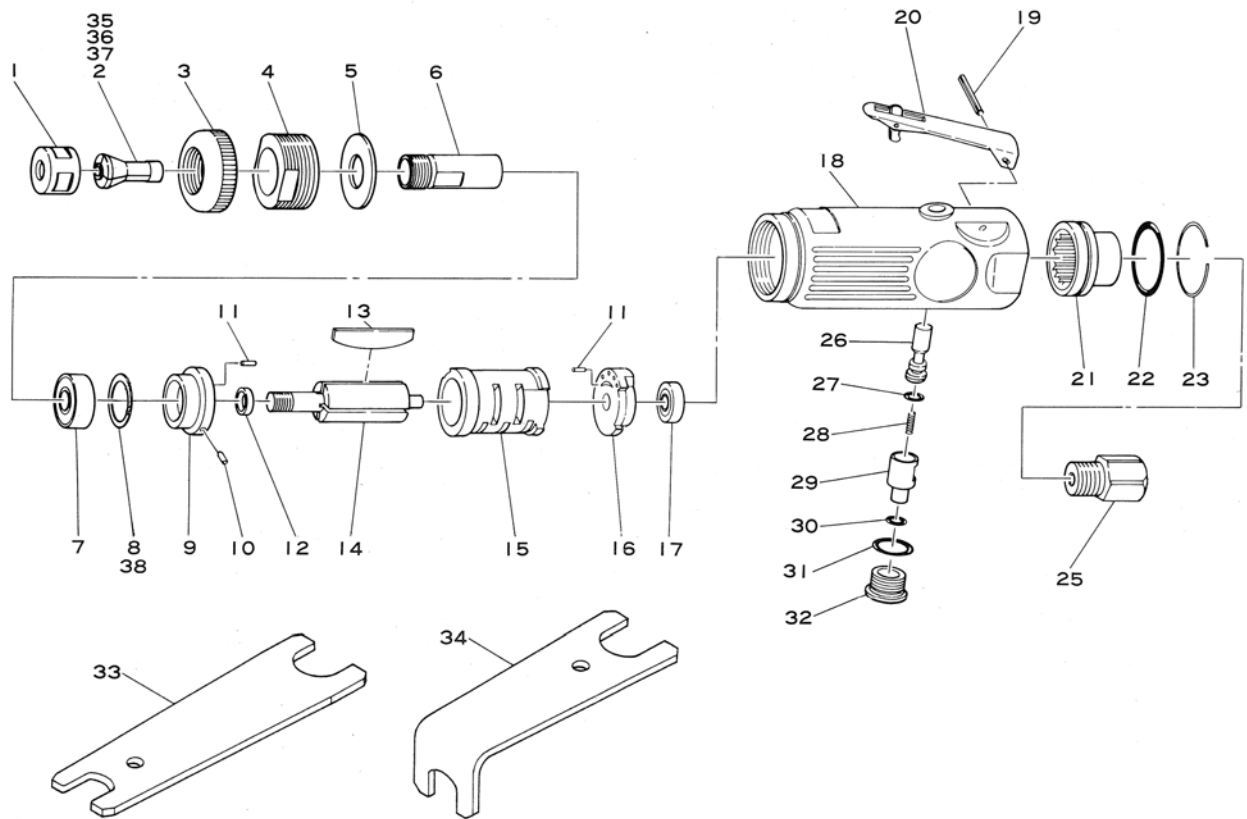

Ref. No.	Parts No.	Description	Q'ty	Ref. No.	Parts No.	Description	Q'ty
1	350-23	Collet Nut	1	20	350-2L	Throttle Lever	1
2	330-24	1/4" Collet (Standard)	1	21	620-18	Deflector	1
3	620-34	Housing Cap	1	22	620-28	O-Ring	1
4	620-14	Lock Ring	1	23	620-30	Retaining Ring	1
5	620-20	Washer	1	25	180-1SC	Inlet Bushing incl. Screen (680-28A)	1
6	350-22	Spindle	1	26	350-5	Valve Stem	1
7	6000-ZZ	Ball Bearing	1	27	P-5	O-Ring	1
8	350-20	Shim (0.03mm)	1	28	350-7	Valve Spring	1
9	620-10	Front Plate	1	29	350-8	Air Regulator	1
10	25-3.5	Roll Pin (2.5-3.5mm)	1	30	P-8	O-Ring	1
11	25-5	Roll Pin (2.5-5mm)	2	31	P-11	O-Ring	1
12	350-18	Collar	1	32	350-10	Valve Screw	1
13	350-16	Rotor Blade	4	33	350-28	Spanner Wrench	1
14	350-15	Rotor	1	34	890-34	Spanner Wrench (Angle Type)	1
15	680-1	Cylinder	1	35	330-25	1/8" Collet (Optional)	
16	620-9	Rear Plate	1	36	330-26	3mm Collet (Optional)	
17	626-ZZ	Ball Bearing	1	37	330-19	6mm Collet (Optional)	
18	890-5SI	Motor Housing incl. Valve Bush (350-4)	1	38	350-29	Shim (0.05mm) (Optional)	
19	30-24	Roll Pin (3-24mm)	1				