

# E2006S

## 1/4" Angle Die Grinder Rear Exhaust

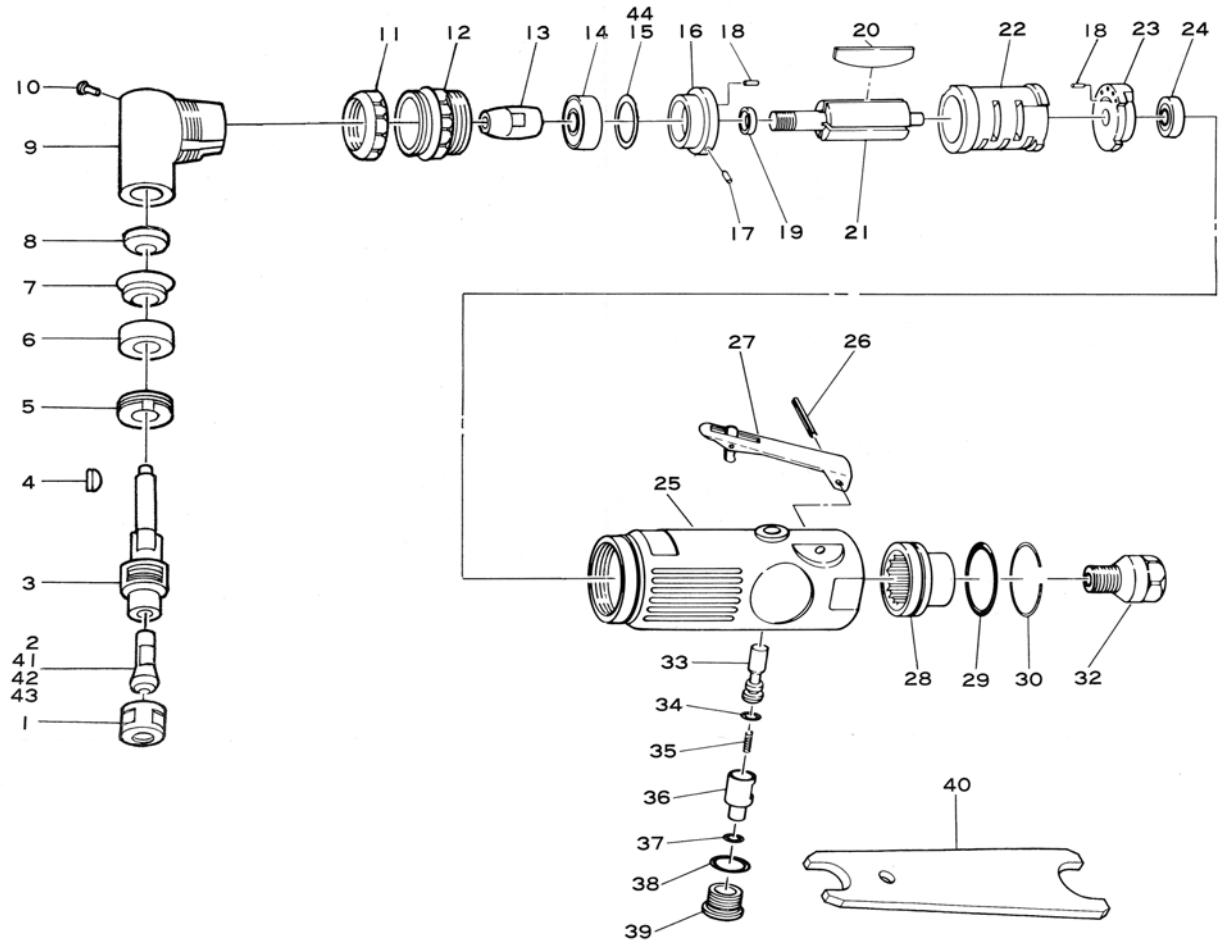

Ref. No.	Parts No.	Description	Q'ty	Ref. No.	Parts No.	Description	Q'ty
1	330-23	Collet Nut	1	23	610-12	Rear Plate	1
2	330-24	1/4" Collet	1	24	696-ZZ	Ball Bearing	1
3	115-22	Spindle	1	25	610-1	Motor Housing incl. Valve Bush (330-4)	1
4	115-36	Key	1	26	30-24	Roll Pin (3-24mm)	1
5	115-32	Spindle Nut	1	27	350-2L	Throttle Lever	1
6	608-LLU	Ball Bearing	1	28	610-29	Deflector	1
7	115-34B	Bevel Gear	1	29	620-28	O-Ring	1
8	R4-ZZ	Ball Bearing	1	30	610-30	Retaining Ring	1
9	115-31	Angle Head	1	32	610-2SC	Inlet Bushing incl. Screen (610-33)	1
10	115-1	Grease Plug	1	33	330-5	Valve Stem	1
11	115-27	Angle Head Coupling Nut	1	34	P-4	O-Ring	1
12	115-26	Motor Clamp Nut	1	35	350-7	Valve Spring	1
13	115-33B	Pinion Gear	1	36	330-8	Air Regulator	1
14	608-ZZ	Ball Bearing	1	37	P-8	O-Ring	1
15	330-20	Shim (0.03mm)	1	38	P-10	O-Ring	1
16	115-19	Front Plate	1	39	330-10	Valve Screw	1
17	25-3.5	Roll Pin (2.5-3.5mm)	1	40	330-28	Spanner Wrench (11x17mm)	2
18	25-5	Roll Pin (2.5-5mm)	2	◆41	330-25	1/8" Collet	
19	330-18	Collar	1	◆42	330-26	3mm Collet	
20	330-16	Rotor Blade	4	◆43	330-19	6mm Collet	
21	330-15	Rotor	1	◆44	330-29	Shim (0.05mm)	
22	330-17	Cylinder	1				

◆Option