

E1305

3/8" Sq. Drv. Palm Grip Impact Wrench

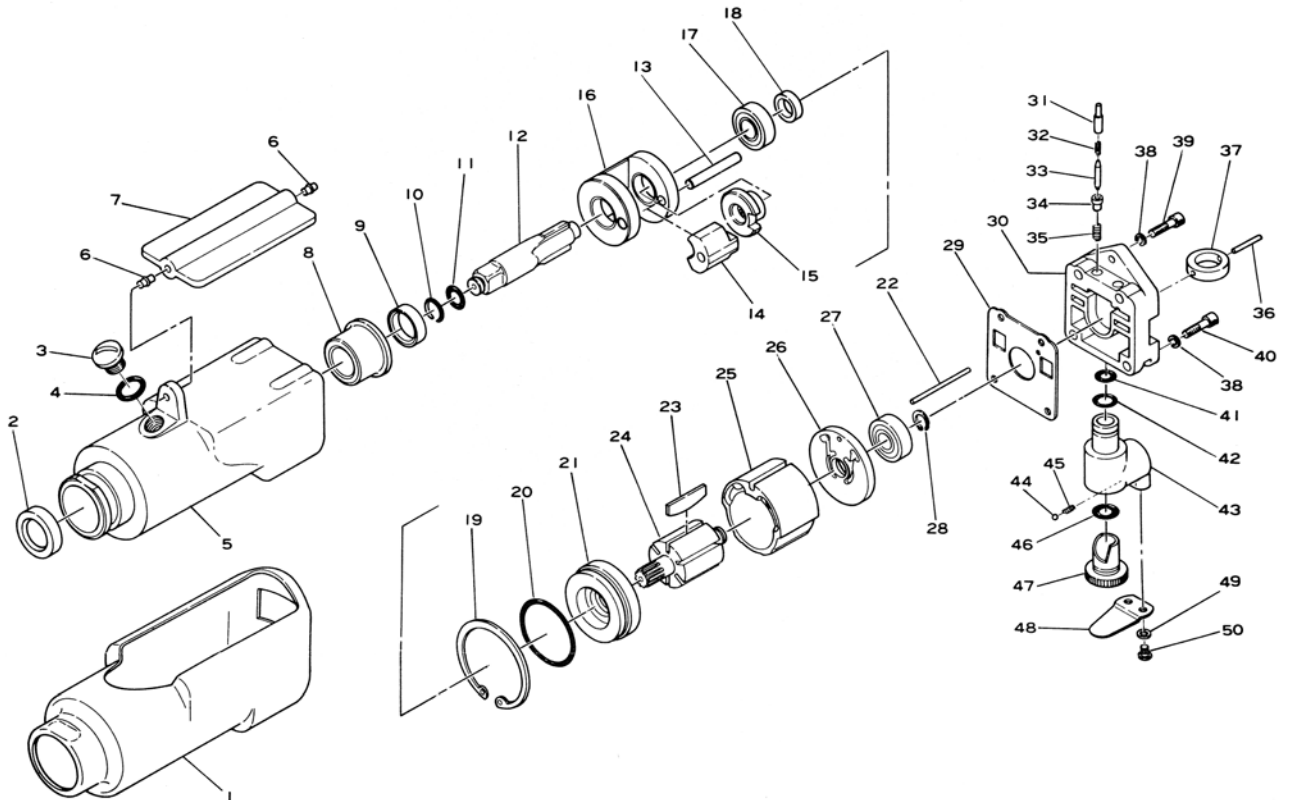

Ref. No.	Parts No.	Description	Q'ty	Ref. No.	Parts No.	Description	Q'ty
1	456-2R	Housing Cover	1	26	455-2	Rear Plate	1
2	450-17	Oil Seal	1	27	626	Ball Bearing	1
3	450-29	Plug	1	28	JS-6	Retaining Ring	1
4	P-5	O-Ring	1	29	455-18	Motor Gasket	1
5	456-3	Motor Housing incl. Seal & Bush (450-17, 450-20)	1	30	456-4A	Housing Cap	1
6	450-19	Throttle Lever Pin	2	31	456-10	Plunger	2
7	455-9	Throttle Lever	1	32	455-19	Plunger Spring	2
8	450-20	Anvil Bushing	1	33	455-11	Valve Pin	2
9	450-54	Collar	1	34	455-21	Valve	2
10	450-10	Socket Retainer Ring	1	35	455-20	Valve Spring	2
11	450-11	O-Ring	1	36	20-16	Roll Pin (2-16mm)	1
12	450-50	3/8" Sq. Anvil	1	37	455-6A	Collar	1
13	450-52	Hammer Pin	1	38	HSW-40	Washer	4
14	450-51	Hammer Dog	1	39	Z-832-250	Cap Screw	2
15	450-53	Cam	1	40	Z-832-160	Cap Screw	2
16	455-45	Hammer Cage	1	41	455-6	O-Ring	1
17	EE-3	Ball Bearing	1	42	930-52	O-Ring	1
18	450-18	Oil Seal	1	43	455-5B	Inlet Bushing	1
19	JO-40	Retaining Ring	1	44	SB-1/8	Steel Ball	1
20	450-35	O-Ring	1	45	450-45	Regulator Spring	1
21	455-3	Front Plate	1	46	P-8	O-Ring	1
22	455-17	Motor Pin	1	47	450-8	Air Regulator	1
23	450-37	Rotor Blade	6	48	450-14	Regulator Retainer	1
24	450-9	Rotor	1	49	AT-40	Washer	2
25	450-56	Cylinder	1	50	JBM40-60	Screw	2