

E-1140 / E-1140M (Magnet Type) 4mm Screw Driver

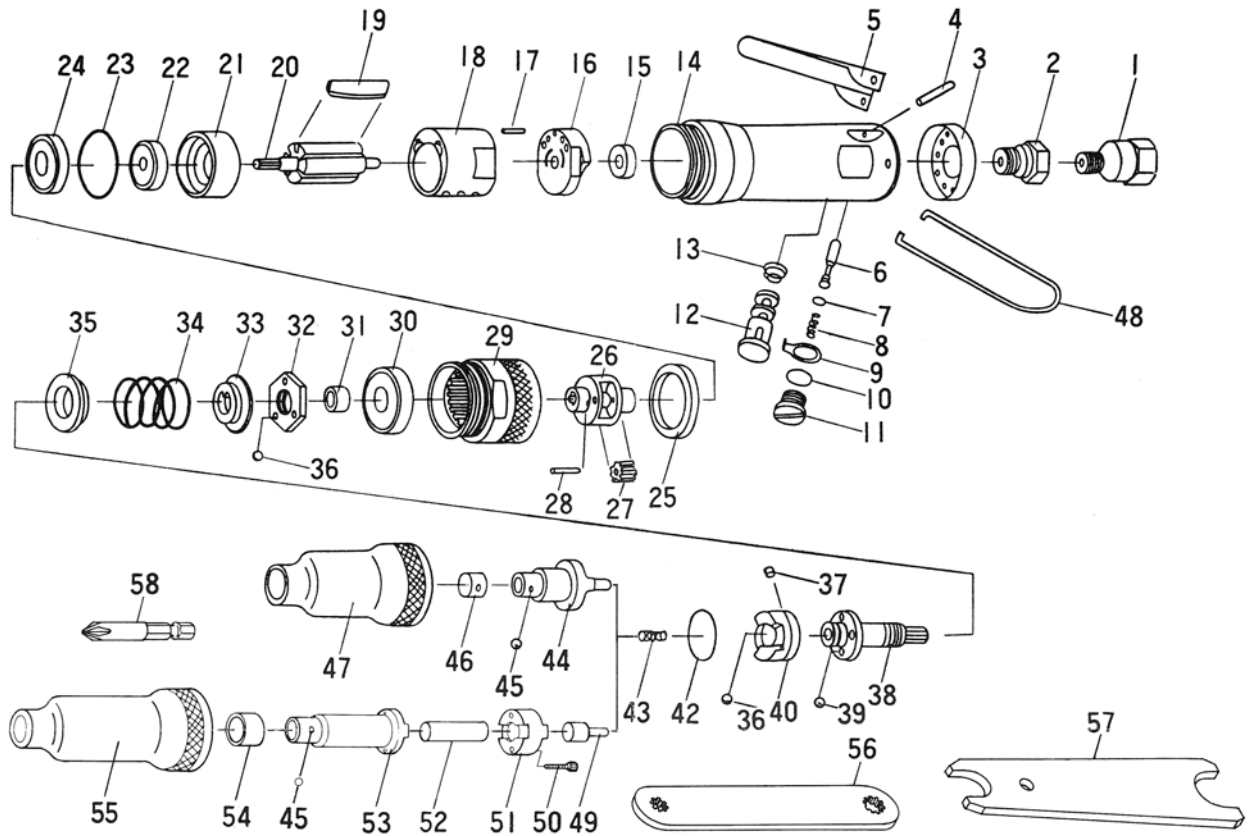

Ref. No.	Parts No.	Description	Q'ty	Ref. No.	Parts No.	Description	Q'ty
1	460-51	Adaptor	1	29	460-27	Internal Gear	1
2	460-1	Inlet Bushing	1	30	6000	Ball Bearing	1
3	460-2	Exhaust Deflector	1	31	460-45	Collar	1
4	30-24	Roll Pin (3-24mm)	1	32	460-46	Adjust Nut	1
5	350-2	Throttle Lever	1	33	460-47	Adjust Nut Seat	1
6	460-5	Valve Stem	1	34	460-43	Clutch Spring	1
7	P-4	O-Ring	1	35	460-42	Clutch Spring Seat	1
8	460-10	Valve Spring	1	36	SB-25	Steel Ball	14
9	460-15	Reverse Retainer	1	37	460-48	Dog Plug	1
10	P-7	O-Ring	1	38	460-38	Clutch Spindle	1
11	982-17	Valve Screw	1	39	SB-40	Steel Ball	4
12	460-12	Reverse Valve	1	40	460-37	Dog	1
13	460-14	Reverse Spring	1	42	460-39	Dog Retainer	1
14	460-16	Motor Housing incl. Bushes & Steel Ball (460-13, 982-24, SB-1/8x4)	1	43	460-44	Centre Spring	1
				☆44	460-36	Work Spindle	1
15	605	Ball Bearing	1	45	SB-1/8	Steel Ball	1
16	460-17	Rear Plate	1	☆46	460-34	Ball Retainer	1
17	15-16	Roll Pin (1.5-16mm)	1	☆47	460-35	Clutch Case	1
18	460-21	Cylinder	1	48	982-20	Hanger	1
19	460-22	Rotor Blade	5	★49	460-37M	Spindle Pin	1
20	460-20	Rotor	1	★50	Z-M30-100	Cap Screw	2
21	460-23	Front Plate	1	★51	460-39M	Clutch Joe	1
22	626	Ball Bearing	1	★52	460-38M	Magnet	1
23	620-28	O-Ring	1	★53	460-36M	Work Spindle	1
24	608	Ball Bearing	1	★54	460-34	Ball Retainer	1
25	460-28	Spacer	1	★55	460-35M	Clutch Case	1
26	460-29	Attachment Spindle	1	56	460-50	Adjust Spanner	1
27	460-31	Idler Gear	2	57	330-28	Spanner Wrench	1
28	310-19	Planet Pin	2	58	181-51	+ Bit No.2	1

☆For E-1140 only
★For E-1140M only

Printed in Japan
★★Jan. 1999