

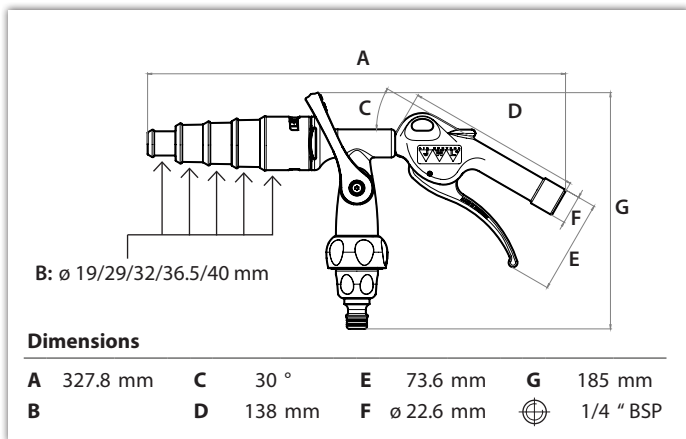

Optional - washing nozzle



Watch video



Materials

Handle and trigger	Acetal plastic
Valve	Acetal plastic
Gaskets/O-rings	Nitrile
Nozzles	POM
Spring	Hardened spring wire
Internal nozzle	Steel, electrically galvanised

Jet Flusher

Efficient and quick flushing of your cooling system

Engine coolant degrades over time and most likely contaminates with abrasive particles and foreign materials. Prevent this from happening by flushing the cooling system occasionally and when replacing cooling system parts. The JWL Jet Flusher works without use of solvents or harsh chemicals.

The combination of compressed air and water increases the water pressure compared to the main water supply - and with it the complete efficiency of the cooling system flushing.

The Jet Flusher is equipped with regulations for both air and water flow. This allows the water supply to be shut off directly at the Jet Flusher instead of at the water tap. The Jet Flusher is designed with a built-in swivel that allows the connected water hose to rotate freely around the Jet Flusher.

As standard the JWL Jet Flusher is delivered with a Jet Flusher nozzle. This can easily be changed to other nozzles e.g. the washer nozzle by using the built-in bayonet connection. The water is connected either by using the supplied nipple (1/2" / ∅ 13 mm) suitable for regular water connectors or by using the built-in 3/4" GHT water hose thread.

Features:

- Effective flushing - without use of harsh chemicals
- Multi functional - replaceable nozzle
- Individual regulations of both air and water flow
- Great mobility

Extreme care should be taken when flushing cooling systems in poor condition



Specifications

Working pressure		6 - 10 Bar (87 - 145 psi)
Air consumption		minimum: 200 l/min. / 2,5 HP air compressor
Weight		~0,40 kg
Water connection		1/2" Nipple for water coupling / 3/4" GHT thread
Air connection		1/4" internal thread (BSP)



Made in Denmark

www.jwl.dk