

## VERTICAL LIFTING CLAMP (Simple clamp-release type)

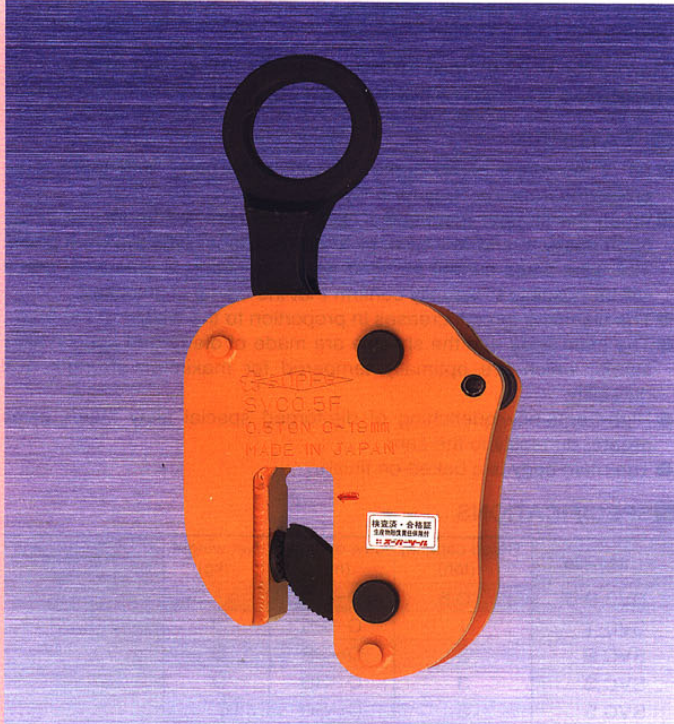

### SVC 0.5F

Clamp for the vertical lifting of steel plates and steel structures (Lightweight design)

#### FEATURES

- All of the major components are within the body, and there is no projection from the body for easy operation.
- The clamping force increases in proportion to the weight of the load.
- Compact, lightweight and easy to operate design
- Simple and easy operation:  
The cam will retract into the body and the clamp will open when the shackle is pushed in. The work piece can be clamped by lightly pulling the shackle out.
- When the sling wire slackens due to the load coming to rest on the floor, the spring loaded initial clamping force will prevent the clamp from detaching from the work piece.
- The main body is made by welding of high-tensile steel, and has extreme strength and durability.
- High-frequency quenching of die-forged special alloy steels gives greater durability to the cam.
- The main body is a baked-on finished.

#### SPECIFICATIONS

Item No.	Rated capacity (ton)	Jaw opening (mm)	Net weight (kg)	Remarks
SVC 0.5F	0.5	0~19	1.7	

#### EXAMPLES OF USE

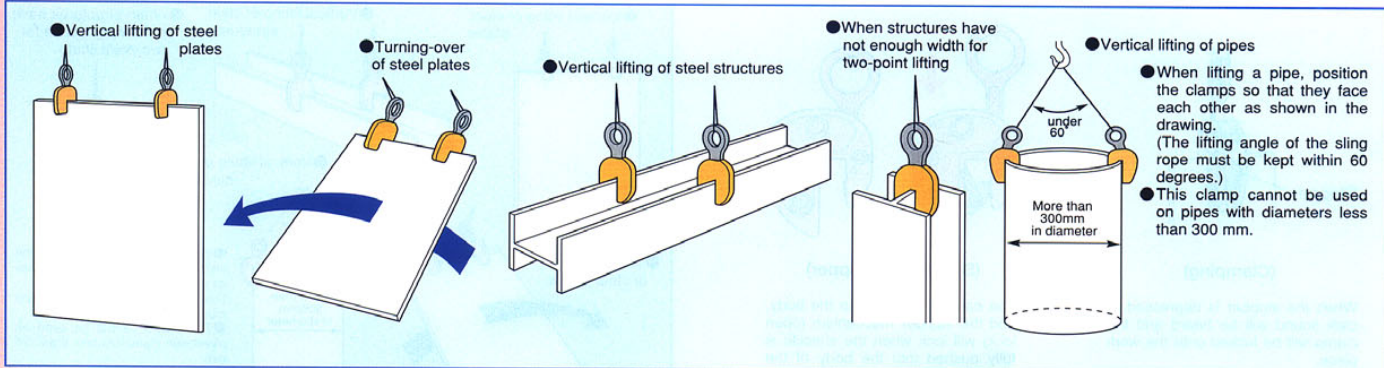

⚠ Always lift work pieces at 2 or more points for safety.

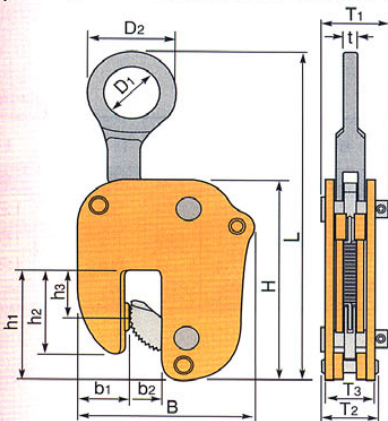

#### DIMENSIONS TABLE

Item No.	L (MAX)	H	h <sub>1</sub>	h <sub>2</sub>	h <sub>3</sub>	B	b <sub>1</sub>	b <sub>2</sub>	D <sub>1</sub>	D <sub>2</sub>	T <sub>1</sub>	T <sub>2</sub>	T <sub>3</sub>	t
SVC 0.5F	230	140	77	58	33	112	32	21	35	56	44	37	31	9

(Unit:mm)