

# E2001S

## Small Die Grinder - Rear Exhaust

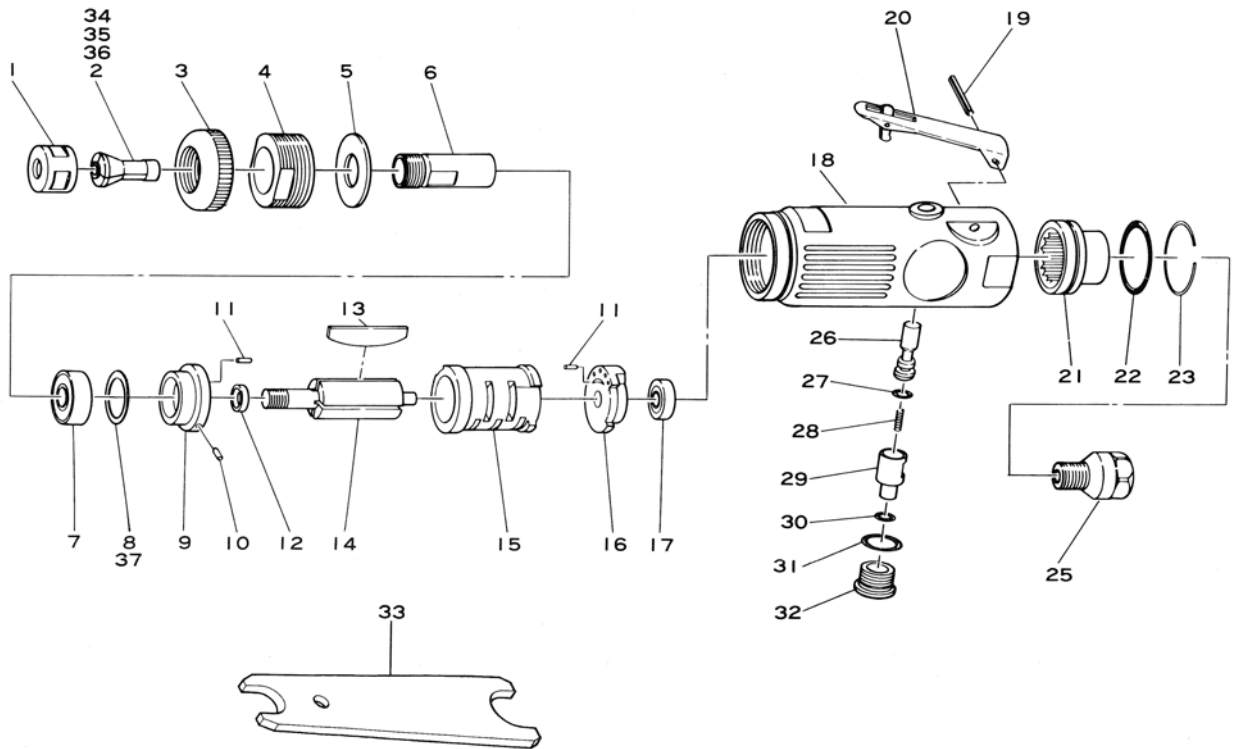

Ref. No.	Parts No.	Description	Q'ty	Ref. No.	Parts No.	Description	Q'ty
1	330-23	Collet Nut	1	19	30-24	Roll Pin (3-24mm)	1
2	330-24	1/4" Collet (Standard)	1	20	350-2L	Throttle Lever	1
3	330-27	Housing Cap	1	21	610-29	Deflector	1
4	610-26	Lock Ring	1	22	620-28	O-Ring	1
5	610-25	Washer	1	23	610-30	Retaining Ring	1
6	330-22	Spindle	1	25	610-2SC	Inlet Bushing incl. Screen (610-33)	1
7	608-ZZ	Ball Bearing	1	26	330-5	Valve Stem	1
8	330-20	Shim (0.03mm)	1	27	P-4	O-Ring	1
9	610-19	Front Plate	1	28	350-7	Valve Spring	1
10	25-3.5	Roll Pin (2.5-3.5mm)	1	29	330-8	Air Regulator	1
11	25-5	Roll Pin (2.5-5mm)	2	30	P-8	O-Ring	1
12	330-18	Collar	1	31	P-10	O-Ring	1
13	330-16	Rotor Blade	4	32	330-10	Valve Screw	1
14	330-15	Rotor	1	33	330-28	Spanner Wrench	2
15	330-17	Cylinder	1	34	330-25	1/8" Collet (Optional)	
16	610-12	Rear Plate	1	35	330-26	3mm Collet (Optional)	
17	696-ZZ	Ball Bearing	1	36	330-19	6mm Collet (Optional)	
18	610-1SI	Motor Housing incl. Valve Bush (330-4)	1	37	330-29	Shim (0.05mm) (Optional)	